



**AGENDA FOR THE
ORDINARY COUNCIL MEETING
TO BE HELD ON
WEDNESDAY**

18 March 2015

SHIRE OF MINGENEW



Shire of Mingenew

Ordinary Council Meeting Notice Paper

18 March 2015

Madam President and Councillors,

An ordinary meeting of Council is called for Wednesday, 18 March 2015, in the Council Chambers, Victoria Street, Mingenew, commencing at 4.00 pm.

Martin Whitely
Chief Executive Officer

15 March 2015

MINGENEW SHIRE COUNCIL

DISCLAIMER

No responsibility whatsoever is implied or accepted by the Mingenew Shire Council for any act, omission or statement or intimation occurring during Council/Committee meetings or during formal/informal conversations with staff. The Mingenew Shire Council disclaims any liability for any loss whatsoever and howsoever caused arising out of reliance by any person or legal entity on any such act, omission or statement occurring during Council/Committee meetings or discussions. Any person or legal entity that acts or fails to act in reliance upon any statement does so at that person's or legal entity's own risk.

In particular and without derogating in any way from the broad disclaimer above, in any discussion regarding any planning application or application for a licence, any statement or limitation of approval made by a member or officer of Mingenew Shire Council during the course of any meeting is not intended to be and is not taken as notice of approval from the Mingenew Shire Council. The Mingenew Shire Council warns that anyone who has an application lodged with the Mingenew Shire Council must obtain and only should rely on **WRITTEN CONFIRMATION** of the outcome of the application, and any conditions attaching to the decision made by the Mingenew Shire Council in respect of the application.

CHIEF EXECUTIVE OFFICER

18 MARCH 2015

Table of Contents

1.0	DECLARATION OF OPENING/ANNOUNCEMENT OF VISITORS	1
2.0	RECORD OF ATTENDANCE/APOLOGIES/APPROVED LEAVE OF ABSENCE	1
2.1	PRESENT	1
2.2	APOLOGIES	1
3.0	RESPONSE TO PREVIOUS PUBLIC QUESTIONS TAKEN ON NOTICE	1
4.0	PUBLIC QUESTION TIME/PETITIONS/DEPUTATIONS/PRESENTATIONS/SUBMISSIONS	1
4.1	PRESENTATION	1
5.0	APPLICATIONS FOR LEAVE OF ABSENCE	1
6.0	DECLARATIONS OF INTEREST	1
7.0	CONFIRMATION OF PREVIOUS MEETINGS' MINUTES	1
7.1	ORDINARY MEETING HELD 18 TH MARCH 2015	1
8.0	ANNOUNCEMENTS BY PRESIDING PERSON WITHOUT DISCUSSION	1
9.0	OFFICERS REPORTS	
9.1	CHIEF EXECUTIVE OFFICER	1
9.1.1	REGIONAL ROAD GROUP FUNDING	1
9.2	FINANCE	4
9.2.1	FINANCIAL STATEMENTS FOR MONTH ENDING 28 TH FEBRUARY, 2015	4
9.2.2	MID WEST REGIONAL COUNCIL – FINANCIAL REPORT FOR PERIOD ENDING 31 MARCH 2014	32
9.2.3	ACCOUNTS FOR PAYMENT ENDING MONTH 28 TH FEBRUARY, 2015	75
9.3	PLANNING AND BUILDING	84
9.3.1	PROPOSED EQUIPMENT SHELTER ON LOT 33 DEPOT HILL ROAD, MINGENEW	84
10.0	ELECTED MEMBERS/MOTIONS OF WHICH PREVIOUS NOTICE HAS BEEN GIVEN	99
11.0	NEW BUSINESS OF AN URGENT NATURE INTRODUCED BY DECISION OF THE MEETING	99
11.1	ELECTED MEMBERS	99
11.2	STAFF	99
12.0	CONFIDENTIAL ITEMS	99
13.0	TIME AND DATE OF NEXT MEETING	99
14.0	CLOSURE	99

SHIRE OF MINGENEW

AGENDA FOR ORDINARY MEETING OF COUNCIL TO BE HELD IN COUNCIL CHAMBERS ON 18 March 2015 COMMENCING AT 4.00pm

- 1.0 DECLARATION OF OPENING/ANNOUNCEMENT OF VISITORS
- 2.0 RECORD OF ATTENDANCE/APOLOGIES/APPROVED LEAVE OF ABSENCE
- 3.0 RESPONSE TO PREVIOUS PUBLIC QUESTIONS TAKEN ON NOTICE
- 4.0 PUBLIC QUESTION TIME/PETITIONS/DEPUTATIONS/PRESENTATIONS/SUBMISSIONS
- 5.0 APPLICATIONS FOR LEAVE OF ABSENCE
- 6.0 DECLARATIONS OF INTEREST
- 7.0 CONFIRMATION OF PREVIOUS MEETING MINUTES
- 7.1 *ORDINARY MEETING HELD 18 FEBRUARY 2015*
- 8.0 ANNOUNCEMENTS BY PRESIDING PERSON WITHOUT DISCUSSION
- 9.0 OFFICERS REPORTS
- 9.1 CHIEF EXECUTIVE OFFICER

9.1.1 REGIONAL ROAD GROUP FUNDING

Location/Address: Shire of Mingenew
Name of Applicant: Shire of Mingenew
Disclosure of Interest: Nil
File Reference: ADM097
Date: 13th March 2015
Author: Martin Whitely, Chief Executive Officer

Summary

To consider and accept a submission for the Mid West Regional Road Group Meeting to be held on Friday 27th March 2015.

Attachment

Nil

Background

At the February 2015 Concept Forum I mentioned to Council that there were several anomalies with the 2014/15 and 2015/16 Regional Road Group and 2014/15 State Black Spot funded projects.

These anomalies were in relation to;

1. Main Roads funding of \$100,000 allocated to reconstruct a 1km section on the Mingenew Mullewa Road as part of the 2014/15 Regional Road Group program

2. Funds of \$70,733 allocated to complete an upgrade of the Mingenew Morawa / Yandanooka North East Road intersection as part of the 2014/15 State Black Spot program
3. Funding of \$149,000 allocated to replace and extend culverts on a 6.59km section of the Mingenew Mullewa Rd under the 2015/16 Regional Road Group program.

The Regional Road Group North Midland Sub Group meeting was held in Coorow on Thursday 12th March 2015. Prior to this meeting the CEO had spoken to Mr Bernie Miller on several occasions indicating to Mr Miller that it was the Shire's intention to;

1. Request that the \$100,000 allocated to SLK 24.00 – SLK 25.00 Mingenew Mullewa Road for the 2014/15 financial year be carried forward to the 2015/16 financial year,
2. Request that a new project be submitted for the 2015/16 financial year to replace the project where \$149,000 funding had been allocated for SLK 4.10 – SLK 10.69 on the Mingenew Mullewa Road to replace and extend culverts given that these works had already been carried out, and
3. Release the \$70,733 State Black Spot funds back to the Mid West Regional Road Group in lieu of the Shire of Mingenew increasing the scope of works at the intersection and staging the project over the 2016/17 and 2017/18 financial years.

At the Sub Group Meeting the above requests were put to the group. While there was no argument with the Shire of Mingenew handing the State Black Spot funding back to the group the Sub Group were not in favour of allowing the 2014/15 funds to be carried forward and were very much not in favour of allowing the Shire to make a new submission for the 2015/16 Regional Road Group funding to replace a project that had previously been approved yet has already been completed.

Ultimately there was no motion seconded by the group to vote on the 2014/15 funds being carried forward, nor the Shire being allowed to resubmit another project for the 2015/16 financial year. As a result the North Midlands did not endorse either of these projects.

Comment

It is very disappointing that the North Midlands Sub Group were not supportive of the CEO's request to carry forward the \$100,000 funding for the 2014/15 Mingenew Mullewa Rd project to the 2015/16 financial year and equally disappointing that the group did not allow the CEO to resubmit another project to replace the project previously endorsed by the Regional Road Group for the 2015/16 financial year.

I understand the consequences that result from Shire's not spending their full allocation in any given year and potentially the effect this has on the reduction of available funds in future years, however I would have expected that given the staffing issues that have arisen in the past 12 months within the Shire the group may have shown some leniency on the matter. This has certainly been my experience as a Technical Group member with the Wheatbelt South Regional Road Group for the four prior to arriving in Mingenew.

There are significant financial implications if the Shire does not receive the \$100,000 allocated for the 2014/15 financial year and \$149,000 allocated for the 2015/16 financial year. These amounts have been allocated to complete specific projects and make up 2/3rds of the total project costs, so effectively if both of these amounts are not secured then the Shire would be \$249,000 out of pocket if they were to complete the projects without the Main Roads funding. Most likely, the Shire would have to defer these projects until future funding was made available as it would be difficult to find discretionary funding of these amounts within the 2014/15 or 2015/16 budgets.

Consultation

Bernie Miller, Main Roads

Statutory Environment

Nil

Policy Implications

Nil

Financial Implications

1. The loss of \$100,000 funding in the 2014/15 financial year, or alternatively the Shire retaining the \$100,000 funding and paying contractors \$150,000 to complete the works, as the Shire works crew would not have the capacity to complete the works ourselves this financial year. This would require an Absolute Majority vote of Council since these works are not allocated in the 2014/15 Budget.
2. Without being able to resubmit another project for the 2015/16 financial year the Shire will lose the \$149,000 funding allocation for the Regional Road Group which would result in a reduction in the scope of works for the 2015/16 road program.

Strategic Implications

Nil

Voting Requirements

Absolute Majority

OFFICER RECOMMENDATION – ITEM 9.1.1

That Council advises Main Roads of the following;

1. As a result of staffing issues experienced by the Shire of Mingenew in the past 12 months Council will not be able to complete the scope of works for one of the Regional Road Group projects and request that the \$100,000 allocated to SLK 24.00 – SLK 25.00 Mingenew Mullewa Road for the 2014/15 financial year be carried forward to the 2015/16 financial year
2. That funds of \$149,000 allocated as part of the 2015/16 Regional Road Group year to replace and extend culverts for SLK 4.10 – SLK 10.69 on the Mingenew Mullewa Road be returned to the Mid West Regional Road Group as a result of the works having already been carried out, and
3. That 2014/15 State Black Spot funds of \$70,733 for the Mingenew Morawa / Yandanooka North East Road intersection is returned to the Mid West Regional Road Group as a result of the Shire of Mingenew increasing the scope of works at the intersection and staging the project over two years by way of submitting State Black Spot applications for the 2016/17 and 2017/18 financial years.
4. That Staff and Elected Members of Council are committed to ensure that such anomalies with Main Roads funding do not occur in the future

9.2 FINANCE

9.2.1 FINANCIAL STATEMENTS FOR PERIOD ENDING 28TH FEBRUARY, 2015

Location/Address:	Shire of Mingenew
Name of Applicant:	Shire of Mingenew
Disclosure of Interest:	Nil
File Reference:	ADM0304
Date:	12 th March 2015
Author:	Nita Jane, Manager Finance and Administration
Senior Officer:	Martin Whitely, Chief Executive officer

Summary

The Monthly Statement of Financial Activity report for the period ending 28th February 2015 is presented to Council for adoption.

Attachment

Finance Report for period ending 28th February 2015.

Background

Financial Regulations require a monthly statement of financial activity report to be presented to Council.

Comment

SUMMARY OF FUNDS – SHIRE OF MINGENEW	
Municipal Account	44,484
Business Cash Maximiser (Municipal Funds)	202,791
Trust Account	147,969
Mid-West Regional Council Trust Account	172,087
Reserve Maximiser Account	270,366

Debtor's accounts continue to be monitored with all efforts being made to ensure that monies are recovered. The following remains outstanding as at 28th February 2015:

	Current	30+ Days	60+ Days	90+ Days	TOTAL
Amount	23,303	3,223	240	5,923	34,740

Rates Outstanding at 28th February 2015 were:

	Current	Arrears	TOTAL
Rates	152,608	16,432	169,040
Rubbish	1,643	0	1,643
TOTAL	154,251	16,432	170,683

The Statement of Financial Activities Report contains explanations of Councils adopted variances for the 2014 / 2015 financial year.

Consultation

Chief Executive Officer
Senior Finance Officer

Statutory Environment

Local Government Act 1995 Section 6.4
Local Government (Financial Management) Regulations 1996 Section 34

Policy Implications

Nil

Financial Implications

Financial implications are outlined in comments.

Strategic Implications

Nil

Voting Requirements

Simple Majority

OFFICER RECOMMENDATION – ITEM 9.2.1
--

That the Monthly Statement of Financial Activity for the period 1st July 2014 to 28th February 2015 be received.



SHIRE OF MINGENEW

STATEMENT OF FINANCIAL ACTIVITY

FOR THE PERIOD 1 JULY, 2014 TO 28 FEBRUARY, 2015

TABLE OF CONTENTS

Statement of Financial Activity	2
Statement of Financial Activity Reportable Variances	3
Notes to and Forming Part of the Statement	4 to 27
Supplementary Information	

SHIRE OF MINGENEW
NOTES TO AND FORMING PART OF THE STATEMENT OF FINANCIAL ACTIVITY
FOR THE PERIOD 1 JULY, 2014 TO 28 FEBRUARY, 2015

	NOTE	28/02/15 Y-T-D Actual \$	28/02/15 Y-T-D Budget \$	2014/2015 Total Budget \$	28/02/15 Y-T-D Variance \$	28/02/15 Y-T-D Variance %
REVENUES/SOURCES	1,2					
Governance		25,093	23,871	27,155	1,222	(5%)
General Purpose Funding		2,128,216	2,125,151	2,272,577	3,065	(0%)
Law, Order, Public Safety		19,293	22,370	27,538	(3,077)	14%
Health		218	217	217	1	(0%)
Education and Welfare		66,405	2,708	3,920	63,697	(2352%)
Housing		68,168	62,937	93,112	5,231	(8%)
Community Amenities		61,579	59,441	59,964	2,138	(4%)
Recreation and Culture		88,037	82,826	89,685	5,211	(6%)
Transport		866,990	876,380	2,044,889	(9,390)	1%
Economic Services		7,280	7,605	9,843	(325)	4%
Other Property and Services		101,731	98,124	116,550	3,607	(4%)
		<u>3,433,010</u>	<u>3,361,630</u>	<u>4,745,450</u>	<u>(71,380)</u>	
(EXPENSES)/(APPLICATIONS)	1,2					
Governance		(186,158)	(226,766)	(300,729)	(40,608)	18%
General Purpose Funding		(52,558)	(48,234)	(65,446)	4,324	(9%)
Law, Order, Public Safety		(67,611)	(68,626)	(98,127)	(1,015)	1%
Health		(41,038)	(44,090)	(66,426)	(3,052)	7%
Education and Welfare		(25,505)	(23,174)	(35,957)	2,331	(10%)
Housing		(217,622)	(219,943)	(248,530)	(2,321)	1%
Community Amenities		(94,058)	(99,831)	(163,756)	(5,773)	6%
Recreation & Culture		(704,523)	(629,515)	(853,785)	75,008	(12%)
Transport		(1,704,119)	(1,686,717)	(2,356,757)	17,402	(1%)
Economic Services		(126,134)	(113,239)	(164,240)	12,895	(11%)
Other Property and Services		(96,795)	(91,696)	(111,270)	5,099	(6%)
		<u>(3,316,121)</u>	<u>(3,251,831)</u>	<u>(4,465,023)</u>	<u>64,290</u>	
Adjustments for Non-Cash (Revenue) and Expenditure						
(Profit)/Loss on Asset Disposals	4	5,061	4,848	7,267	213	
Depreciation on Assets		1,190,681	1,182,672	1,454,710	8,009	
Capital Expenditure and Income		38,781				
Purchase Land held for Resale	3	0	0	0	0	0%
Purchase Land and Buildings	3	(237,571)	(246,419)	(276,211)	(8,848)	4%
Purchase Furniture and Equipment	3	(4,645)	(1,818)	(1,818)	2,827	(156%)
Purchase Plant and Equipment	3	(252,299)	(251,112)	(306,612)	1,187	(0%)
Purchase Infrastructure Assets - Roads	3	(616,540)	(644,703)	(1,736,565)	(28,163)	4%
Purchase Infrastructure Assets - Footpaths	3	0	0	0	0	0%
Purchase Infrastructure Assets - Bridges	3	0	0	0	0	0%
Purchase Infrastructure Assets - Drainage	3	0	0	0	0	
Purchase Infrastructure Assets - Rec Areas	3	0	0	0	0	
Proceeds from Disposal of Assets	4	87,773	86,682	131,182	(1,091)	(1%)
Repayment of Debentures	5	(128,119)	(127,371)	(162,587)	748	(1%)
Proceeds from New Debentures	5	170,000	170,000	170,000	0	0%
Transfers to Reserves (Restricted Assets)	6	(25,020)	(6,980)	(97,580)	18,040	(258%)
Transfers from Reserves (Restricted Assets)	6	33,897	0	0	33,897	0%
ADD Net Current Assets July 1 B/Fwd	7	(219,394)	(219,394)	(219,394)	0	
LESS Net Current Assets Year to Date	7	<u>117,664</u>	<u>75,384</u>	<u>888,999</u>	<u>42,280</u>	
Amount Req'd to be Raised from Rates		<u>(1,662,076)</u>	<u>(1,646,180)</u>	<u>(1,646,180)</u>	<u>(15,895)</u>	
Rates per Note 8		1,662,075	1,646,180	1,646,180		
Variance		(0)	(0)	0		

**SHIRE OF MINGENEW
NOTES TO AND FORMING PART OF THE STATEMENT OF FINANCIAL ACTIVITY
FOR THE PERIOD 1 JULY, 2014 TO 28 FEBRUARY, 2015**

Graphical Representation - Source Statement of Financial Activity

Operating Budget v Actual - REVENUE

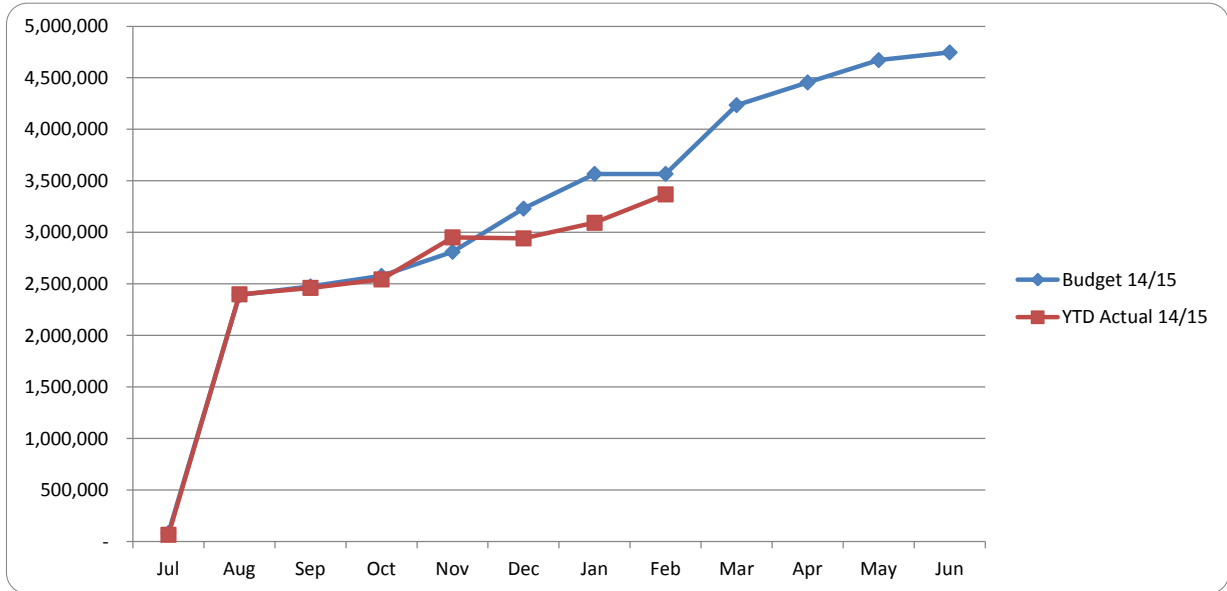

Operating Budget v Actual - EXPENDITURE

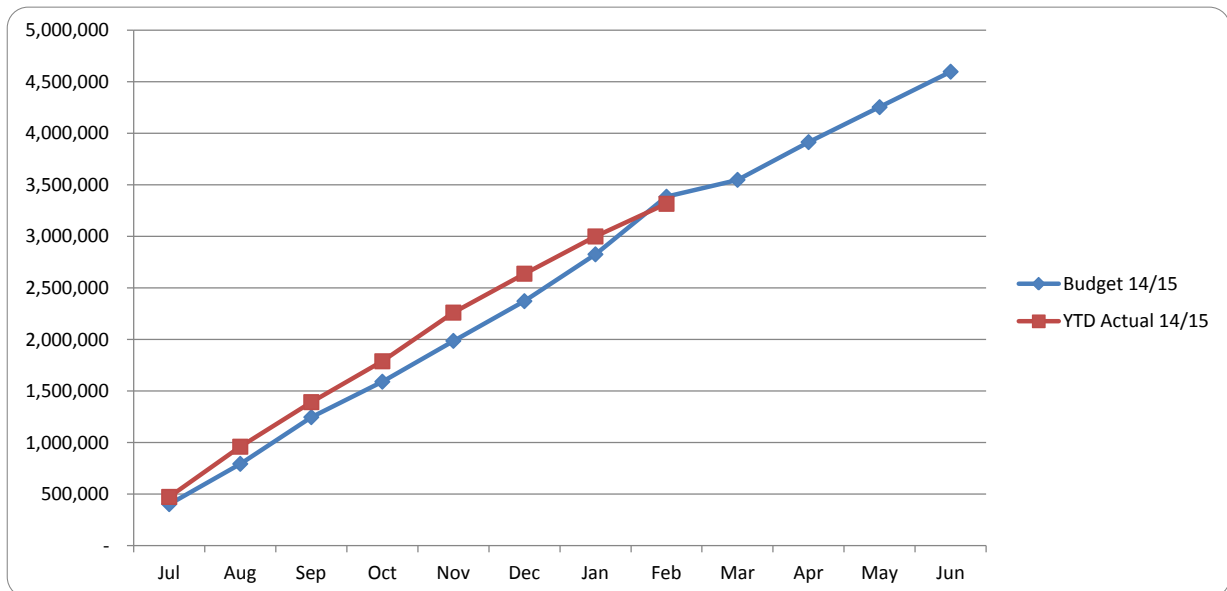

**SHIRE OF MINGENEW
NOTES TO AND FORMING PART OF THE STATEMENT OF FINANCIAL ACTIVITY
FOR THE PERIOD 1 JULY, 2014 TO 28 FEBRUARY, 2015**

Graphical Representation - Source Statement of Financial Activity

Capital Budget v Actual - REVENUE

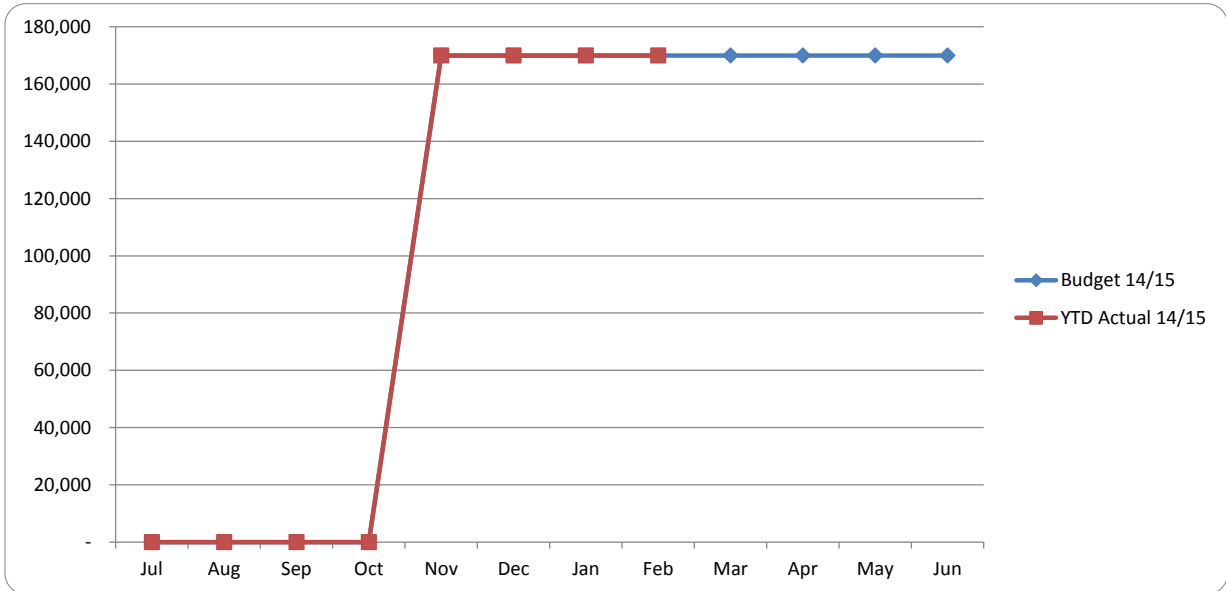

Capital Budget v Actual - EXPENDITURE

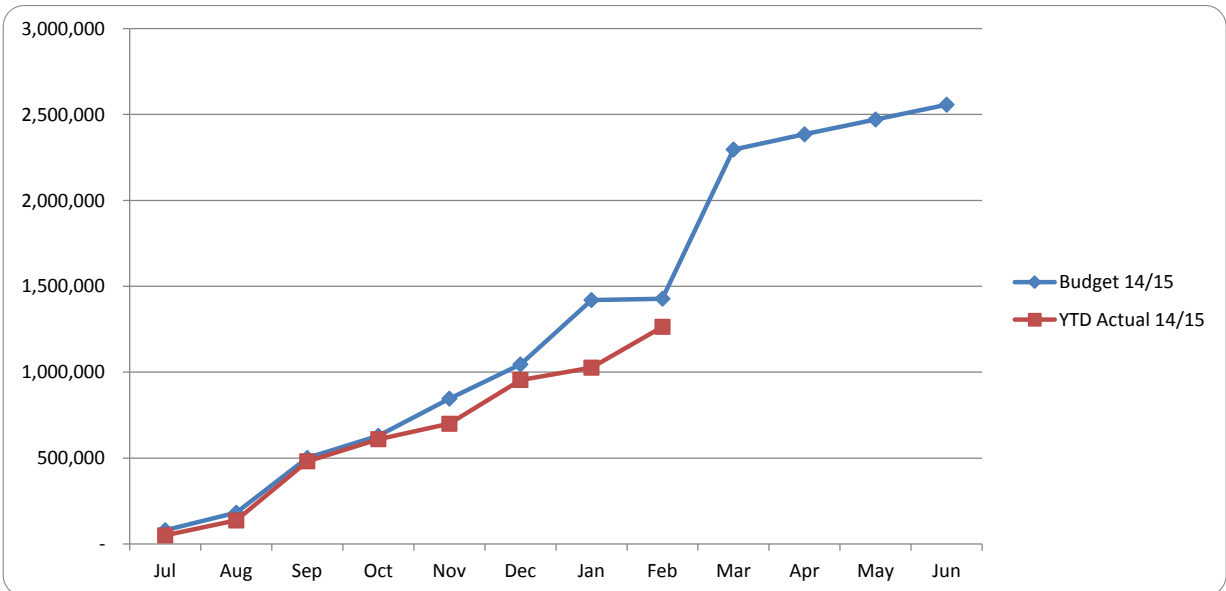

SHIRE OF MINGENEW

**NOTES TO AND FORMING PART OF THE STATEMENT OF FINANCIAL ACTIVITY
FOR THE PERIOD 1 JULY, 2014 TO 28 FEBRUARY, 2015**

Statement of Financial Activity - Reportable Variances

REVENUES/SOURCES

Education & Welfare	(2352%)	64,000	Lotterywest Grant for Men's Shed not budgeted
---------------------	---------	--------	---

(EXPENSES)/(APPLICATIONS)

Governance	18%	6,274	Computer software & licensing - new modules not purchased
		1,328	Councillor training underspent
		1,445	Staff training - timing
		3,173	Staff conferences - timing
		1,974	CEO recruitment - underspent
Recreation & Culture	(12%)	21,393	Increase in Administration Allocations due to payouts
		8,787	Public Gardens & Reserves - over budget
		29,385	Sporting Complex and Amenities - over budget
Economic Services	(11%)	12,105	Increase in Administration Allocations due to payouts
		1,417	MIG office mtce close to full annual spend

CAPITAL EXPENDITURE AND INCOME

Transfers to Reserves (Restricted Assets)	(258%)	-25,020	Final reserve transfers to be done at Year End
---	--------	---------	--

SHIRE OF MINGENEW
NOTES TO AND FORMING PART OF THE STATEMENT OF FINANCIAL ACTIVITY
FOR THE PERIOD 1 JULY, 2014 TO 28 FEBRUARY, 2015

1. SIGNIFICANT ACCOUNTING POLICIES

The significant accounting policies which have been adopted in the preparation of this statement of financial activity are:

(a) Basis of Accounting

This statement is a special purpose financial report, prepared in accordance with applicable Australian Accounting Standards, other mandatory professional reporting requirements and the Local Government Act 1995 (as amended) and accompanying regulations (as amended).

(b) The Local Government Reporting Entity

All Funds through which the Council controls resources to carry on its functions have been included in this statement.

In the process of reporting on the local government as a single unit, all transactions and balances between those funds (for example, loans and transfers between Funds) have been eliminated.

All monies held in the Trust Fund are excluded from the statement, but a separate statement of those monies appears at Note 9.

(c) Rounding Off Figures

All figures shown in this statement, other than a rate in the dollar, are rounded to the nearest dollar.

(d) Rates, Grants, Donations and Other Contributions

Rates, grants, donations and other contributions are recognised as revenues when the local government obtains control over the assets comprising the contributions. Control over assets acquired from rates is obtained at the commencement of the rating period or, where earlier, upon receipt of the rates.

(e) Goods and Services Tax

In accordance with recommended practice, revenues, expenses and assets capitalised are stated net of any GST recoverable. Receivables and payables are stated inclusive of applicable GST.

(f) Cash and Cash Equivalents

Cash and cash equivalents comprise cash at bank and in hand and short-term deposits that are readily convertible to known amounts of cash and which are subject to an insignificant risk of changes in value.

For the purposes of the Cash Flow Statement, cash and cash equivalents consist of cash and cash equivalents as defined above, net of outstanding bank overdrafts. Bank overdrafts are included as short-term borrowings in current liabilities.

(g) Trade and Other Receivables

Trade receivables, which generally have 30 - 90 day terms, are recognised initially at fair value and subsequently measured at amortised cost using the effective interest rate method, less any allowance for uncollectible amounts.

Collectibility of trade receivables is reviewed on an ongoing basis. Debts that are known to be uncollectible are written off when identified. An allowance for doubtful debts is raised when there is objective evidence that they will not be collectible.

SHIRE OF MINGENEW
NOTES TO AND FORMING PART OF THE STATEMENT OF FINANCIAL ACTIVITY
FOR THE PERIOD 1 JULY, 2014 TO 28 FEBRUARY, 2015

1. SIGNIFICANT ACCOUNTING POLICIES (Continued)

(h) Inventories

General

Inventories are valued at the lower of cost and net realisable value. Net realisable value is the estimated selling price in the ordinary course of business less the estimated costs of completion and the estimated costs necessary to make the sale.

Inventories held from trading are classified as current even if not expected to be realised in the next 12 months.

Land Held for Resale

Land purchased for development and/or resale is valued at the lower of cost and net realisable value. Cost includes the cost of acquisition, development and interest incurred on the financing of that land during its development. Interest and holding charges incurred after development is complete are recognised as expenses.

Revenue arising from the sale of property is recognised in the operating statement as at the time of signing a binding contract of sale.

Land held for resale is classified as current except where it is held as non-current based on Council's intentions to release for sale.

(i) Fixed Assets

All assets are initially recognised at cost. Cost is determined as the fair value of the assets given as consideration plus costs incidental to the acquisition. For assets acquired at no cost or for nominal consideration, cost is determined as fair value at the date of acquisition. The cost of non-current assets constructed by the Local Government includes the cost of all materials used in the construction, direct labour on the project and an appropriate proportion of variable and fixed overhead.

Certain asset classes may be revalued on a regular basis such that the carrying values are not materially different from fair value. Assets carried at fair value are to be revalued with sufficient regularity to ensure the carrying amount does not differ materially from that determined using fair value at reporting date.

(g) Depreciation of Non-Current Assets

All non-current assets having a limited useful life are systematically depreciated over their useful lives in a manner which reflects the consumption of the future economic benefits embodied in those assets.

Depreciation is recognised on a straight-line basis, using rates which are reviewed each reporting period. Major depreciation periods are:

Buildings	30 to 50 years
Furniture and Equipment	4 to 10 years
Plant and Equipment	5 to 15 years
Sealed roads and streets	
clearing and earthworks	not depreciated
construction/road base	50 years
original surfacing and	
major re-surfacing	
- bituminous seals	20 years
- asphalt surfaces	25 years
Gravel roads	
clearing and earthworks	not depreciated
construction/road base	50 years
gravel sheet	10 years
Formed roads (unsealed)	
clearing and earthworks	not depreciated
construction/road base	50 years
Footpaths - slab	40 years
Sewerage piping	100 years
Water supply piping & drainage systems	75 years

SHIRE OF MINGENEW
NOTES TO AND FORMING PART OF THE STATEMENT OF FINANCIAL ACTIVITY
FOR THE PERIOD 1 JULY, 2014 TO 28 FEBRUARY, 2015

1. SIGNIFICANT ACCOUNTING POLICIES (Continued)

(k) Impairment

In accordance with Australian Accounting Standards the Council's assets, other than inventories, are assessed at each reporting date to determine whether there is any indication they may be impaired.

Where such an indication exists, an estimate of the recoverable amount of the asset is made in accordance with AASB 136 "Impairment of Assets" and appropriate adjustments made.

An impairment loss is recognised whenever the carrying amount of an asset or its cash-generating unit exceeds its recoverable amount. Impairment losses are recognised in the Income Statement.

For non-cash generating assets such as roads, drains, public buildings and the like, value in use is represented by the depreciated replacement cost of the asset.

At the time of preparing this report, it is not possible to estimate the amount of impairment losses (if any) as at 30 June 2012.

In any event, an impairment loss is a non-cash transaction and consequently, has no impact on the Monthly Statement of Financial Position from a budgetary perspective.

(l) Trade and Other Payables

Trade and other payables are carried at amortised cost. They represent liabilities for goods and services provided to the Municipality prior to the end of the financial year that are unpaid and arise when the Municipality becomes obliged to make future payments in respect of the purchase of these goods and services. The amounts are unsecured and are usually paid within 30 days of recognition.

(m) Employee Benefits

The provisions for employee benefits relates to amounts expected to be paid for long service leave, annual leave, wages and salaries and are calculated as follows:

(i) Wages, Salaries, Annual Leave and Long Service Leave (Short-term Benefits)

The provision for employees' benefits to wages, salaries, annual leave and long service leave expected to be settled within 12 months represents the amount the municipality has a present obligation to pay resulting from employees services provided to balance date. The provision has been calculated at nominal amounts based on remuneration rates the Council expects to pay and includes related on-costs.

(ii) Annual Leave and Long Service Leave (Long-term Benefits)

(n) Interest-bearing Loans and Borrowings

All loans and borrowings are initially recognised at the fair value of the consideration received less directly attributable transaction costs.

After initial recognition, interest-bearing loans and borrowings are subsequently measured at amortised cost using the effective interest method. Fees paid on the establishment of loan facilities that are yield related are included as part of the carrying amount of the loans and borrowings.

Borrowings are classified as current liabilities unless the Council has an unconditional right to defer settlement of the liability for at least 12 months after the balance sheet date.

Borrowing Costs

Borrowing costs are recognised as an expense when incurred except where they are directly attributable to the acquisition, construction or production of a qualifying asset. Where this is the case, they are capitalised as part of the cost of the particular asset.

SHIRE OF MINGENEW
NOTES TO AND FORMING PART OF THE STATEMENT OF FINANCIAL ACTIVITY
FOR THE PERIOD 1 JULY, 2014 TO 28 FEBRUARY, 2015

1. SIGNIFICANT ACCOUNTING POLICIES (Continued)

(o) Provisions

Provisions are recognised when: The council has a present legal or constructive obligation as a result of past events; it is more likely than not that an outflow of resources will be required to settle the obligation; and the amount has been reliably estimated. Provisions are not recognised for future operating losses.

Where there are a number of similar obligations, the likelihood that an outflow will be required in settlement is determined by considering the class of obligations as a whole. A provision is recognised even if the likelihood of an outflow with respect to any one item included in the same class of obligations may be small.

(p) Current and Non-Current Classification

In the determination of whether an asset or liability is current or non-current, consideration is given to the time when each asset or liability is expected to be settled. The asset or liability is classified as current if it is expected to be settled within the next 12 months, being the Council's operational cycle. In the case of liabilities where Council does not have the unconditional right to defer settlement beyond 12 months, such as vested long service leave, the liability is classified as current even if not expected to be settled within the next 12 months. Inventories held for trading are classified as current even if not expected to be realised in the next 12 months except for land held for resale where it is held as non-current based on Council's intentions to release for sale.

SHIRE OF MINGENEW
NOTES TO AND FORMING PART OF THE STATEMENT OF FINANCIAL ACTIVITY
FOR THE PERIOD 1 JULY, 2014 TO 28 FEBRUARY, 2015

2. STATEMENT OF OBJECTIVE

In order to discharge its responsibilities to the community, the Shire has developed a set of operational and financial objectives. These objectives have been established both on an overall basis and for each of its broad activities/programs.

Council operations as disclosed in this statement encompass the following service orientated activities/programs:

GOVERNANCE

Objective: To provide a decision making process for the efficient allocation of scarce resources.
 Activities: Administration and operation of facilities and services to members of council:
 Other costs that relate to the tasks of assisting elected members and ratepayers on matters which do not concern specific council services.

GENERAL PURPOSE FUNDING

Objective: To collect revenue to fund provision of services.
 Activities: Rates, general purpose government grants and interest revenue.

LAW, ORDER, PUBLIC SAFETY

Health: To ensure a safer community in which to live.
 Activities: Supervision of various local laws, fire prevention, emergency services and animal control.

HEALTH

Objective: To provide an operational framework for good community health.
 Activities: Food quality and pest control, maintenance of child health centre, doctors surgery and dental clinic.

EDUCATION AND WELFARE

Objective: To support the needs of the community in education and welfare.
 Activities: Assistance to playgroup, youth advisory committee and other voluntary services.

HOUSING

Objective: Provide adequate housing to attract an retain staff and non-staff.
 Activities: Maintenance of council owned housing.

COMMUNITY AMENITIES

Objective: Provide services as required by the community.
 Activities: Rubbish collection services, tip operation, noise control, town planning administration, cemetery maintenance, storm water drainage, FM radio retransmitter maintenance and mobile phone installation.

RECREATION AND CULTURE

Objective: To establish and efficiently manage infrastructure and resources which will help the social well being of the community.
 Activities: Maintenance of halls, library, parks, gardens and reserves.

TRANSPORT

Objective: To provide effective and efficient transport services to the community.
 Activities: Construction and maintenance of streets, roads, bridges, cleaning and lighting of streets, traffic signs, depot maintenance and airstrip maintenance.

ECONOMIC SERVICES

Objective: To help promote the Shire and improve its economic well being
 Activities: Regulation and provision of tourism, area promotion, building control, noxious weeds, vermin control, plant nursery and standpipes

OTHER PROPERTY & SERVICES

Activities: Private works, plant repairs

SHIRE OF MINGENEW
NOTES TO AND FORMING PART OF THE STATEMENT OF FINANCIAL ACTIVITY
FOR THE PERIOD 1 JULY, 2014 TO 28 FEBRUARY, 2015

	28 February, 2015 Actual \$	2014/2015 Budget \$
3. ACQUISITION OF ASSETS		
The following assets have been acquired during the period under review:		
<u>By Program</u>		
GOVERNANCE		
Plant & Equipment	40,669	97,500
Furniture & Equipment	1,818	1,818
EDUCATION & WELFARE		
Land & Buildings	90,309	91,319
HOUSING		
Land & Buildings	92,830	104,500
Furniture & Equipment	2,826	0
RECREATION & CULTURE		
Plant & Equipment	4,053	4,035
Land & Buildings	52,368	78,328
TRANSPORT		
Plant & Equipment	207,577	205,077
Land & Buildings	2,064	2,064
Infrastructure - Roads	616,540	1,736,565
	1,111,055	2,321,206

	28 February, 2015 Actual \$	2014/2015 Budget \$
ACQUISITION OF ASSETS		
<u>By Class</u>		
Land Held for Resale	0	0
Land and Buildings	237,571	276,211
Furniture and Equipment	4,645	1,818
Plant and Equipment	252,299	306,612
Infrastructure Assets - Roads	616,540	1,736,565
Infrastructure Assets - Footpaths	0	0
Infrastructure Assets - Bridges	0	0
Infrastructure Assets - Drainage/Floodways	0	0
Infrastructure Assets - Recreation Areas	0	0
	1,111,055	2,321,206

SHIRE OF MINGENEW
NOTES TO AND FORMING PART OF THE STATEMENT OF FINANCIAL ACTIVITY
FOR THE PERIOD 1 JULY, 2014 TO 28 FEBRUARY, 2015

4. DISPOSALS OF ASSETS

The following assets have been disposed of during the period under review:

<u>By Program</u>	Net Book Value		Sale Proceeds		Profit(Loss)	
	2014 / 2015	2014 / 2015	2014 / 2015	2014 / 2015	2014 / 2015	2014 / 2015
	BUDGET	ACTUAL	BUDGET	ACTUAL	BUDGET	ACTUAL
	\$	\$	\$	\$	\$	\$
Governance						
Admin Vehicle (MI 177)	32,796	30,771	33,000	34,091	204	3,320
CEO Vehicle (1 MI)	40,511	0	44,500	0	3,989	0
Transport						
Works Manager Vehicle (MI 108)	37,971	35,400	34,200	34,182	(3,771)	(1,218)
Vibromax Vibrating Roller	27,689	26,663	20,000	19,500	(7,689)	(7,163)
	138,967	92,834	131,700	87,773	(7,267)	(5,061)

<u>By Class</u>	Net Book Value		Sale Proceeds		Profit(Loss)	
	2014 / 2015	2014 / 2015	2014 / 2015	2014 / 2015	2014 / 2015	2014 / 2015
	BUDGET	ACTUAL	BUDGET	ACTUAL	BUDGET	ACTUAL
	\$	\$	\$	\$	\$	\$
Plant & Equipment						
Admin Vehicle (MI 177)	32,796	30,771	33,000	34,091	204	3,320
CEO Vehicle (1 MI)	40,511	0	44,500	0	3,989	0
Works Manager Vehicle (MI 108)	37,971	35,400	34,200	34,182	(3,771)	(1,218)
Vibromax Vibrating Roller	27,689	26,663	20,000	19,500	(7,689)	(7,163)
	138,967	92,834	131,700	87,773	(7,267)	(5,061)

Summary

Profit on Asset Disposals
 Loss on Asset Disposals

2014 / 2015	28/2/2015
BUDGET	ACTUAL
\$	\$
4,193	3,320
(11,460)	(8,381)
<u>(7,267)</u>	<u>(5,061)</u>

SHIRE OF MINGENEW
NOTES TO AND FORMING PART OF THE STATEMENT OF FINANCIAL ACTIVITY
FOR THE PERIOD 1 JULY, 2014 TO 28 FEBRUARY, 2015

5. INFORMATION ON BORROWINGS

(a) Debenture Repayments

Particulars	Principal 1 Jul 14	New Loans		Principal Repayments		Principal Outstanding		Interest Repayments	
		Actual \$	Budget \$	Actual \$	Budget \$	Actual \$	Budget \$	Actual \$	Budget \$
Education & Welfare									
Loan 137 - Senior Citizens Building	106,030	0	0	2,225	4,517	103,805	101,513	3,230	6,392
Housing									
Loan 133 - Triplex (+)	93,708	0	0	9,941	9,941	83,767	83,767	6,233	6,233
Loan 134 - S/C Housing (+)	62,443	0	0	4,999	4,999	57,444	57,444	3,801	3,801
Loan 136 - Staff Housing (#)	132,539	0	0	8,955	6,819	123,584	125,720	8,414	8,414
Loan 142 - Staff Housing	83,751	0	0	8,748	8,748	75,003	75,003	4,144	4,145
Recreation & Culture									
Loan 138 - Pavilion Fit-Out	101,788	0	0	0	4,336	101,788	97,452	3,100	6,137
Transport									
Loan 139 - Roller	66,256	0	0	13,107	13,107	53,149	53,149	4,207	4,207
Loan 141 - Grader	150,860	0	0	21,506	21,506	129,354	129,354	9,052	9,052
Loan 143 - Trucks	156,936	0	0	49,891	49,889	107,045	107,047	6,968	6,968
Loan 144 - Trailer	83,751	0	0	8,748	8,748	75,003	75,003	4,144	4,145
Loan 145 - Vibrating Roller	0	170,000	170,000	0	29,977	0	140,023	0	5,033
	1,038,062	170,000	170,000	128,119	162,587	909,943	1,045,475	53,294	64,527

(+) Loan financed by rental proceeds received from tenants.

(#) Loan financed from rental proceeds received from staff (subsidised) or third party tenants.

All other debenture repayments are to be financed by general purpose revenue.

New Loan 145 - application has been made to WATC and funds received

SHIRE OF MINGENEW
NOTES TO AND FORMING PART OF THE STATEMENT OF FINANCIAL ACTIVITY
FOR THE PERIOD 1 JULY, 2014 TO 28 FEBRUARY, 2015

5. INFORMATION ON BORROWINGS (Continued)

(b) New Debentures - 2014 / 2015

A new debenture has been sourced to fund the purchase of a new vibrating roller.
Loan 145 - application has been made to WATC and funds have been received.

(c) Unspent Debentures

Council had no unspent debentures at 30 June, 2014 nor is it expected to have unspent debenture funds as at 30 June, 2015.

(d) Overdraft

Council has an overdraft facility of \$400,000 with National Australia Bank of which Nil was utilised at 30 June 2014. It is anticipated that this facility will be utilised during the 2014 /2015 financial year.

SHIRE OF MINGENEW
NOTES TO AND FORMING PART OF THE STATEMENT OF FINANCIAL ACTIVITY
FOR THE PERIOD 1 JULY, 2014 TO 28 FEBRUARY, 2015

	28 February, 2015 Actual \$	2014/2015 Budget \$
6. RESERVES		
Cash Backed Reserves		
(a) Land and Building Reserve		
Opening Balance	68,999	68,999
Amount Set Aside / Transfer to Reserve	1,407	42,325
Amount Used / Transfer from Reserve	(27,319)	-
	<u>43,087</u>	<u>111,324</u>
(b) Sportsground Improvement Reserve		
Opening Balance	2,604	2,604
Amount Set Aside / Transfer to Reserve	39	65
Amount Used / Transfer from Reserve	-	-
	<u>2,643</u>	<u>2,669</u>
(c) Plant Replacement Reserve		
Opening Balance	115,239	115,239
Amount Set Aside / Transfer to Reserve	22,191	52,881
Amount Used / Transfer from Reserve	(6,578)	-
	<u>130,852</u>	<u>168,120</u>
(d) Accrued Leave Reserve		
Opening Balance	13,455	13,455
Amount Set Aside / Transfer to Reserve	188	336
Amount Used / Transfer from Reserve	-	-
	<u>13,643</u>	<u>13,791</u>
(e) Aged Persons Units Reserve		
Opening Balance	19,330	19,330
Amount Set Aside / Transfer to Reserve	293	483
Amount Used / Transfer from Reserve	-	-
	<u>19,623</u>	<u>19,813</u>
(f) Street Light Upgrade Reserve		
Opening Balance	13,826	13,826
Amount Set Aside / Transfer to Reserve	209	346
Amount Used / Transfer from Reserve	-	-
	<u>14,035</u>	<u>14,172</u>
(g) Painted Road Reserve		
Opening Balance	4,056	4,056
Amount Set Aside / Transfer to Reserve	66	101
Amount Used / Transfer from Reserve	-	-
	<u>4,122</u>	<u>4,157</u>
(h) Industrial Area Reserve		
Opening Balance	5,056	5,056
Amount Set Aside / Transfer to Reserve	72	126
Amount Used / Transfer from Reserve	-	-
	<u>5,128</u>	<u>5,182</u>

SHIRE OF MINGENEW
NOTES TO AND FORMING PART OF THE STATEMENT OF FINANCIAL ACTIVITY
FOR THE PERIOD 1 JULY, 2014 TO 28 FEBRUARY, 2015

	28 February, 2015 Actual \$	2014/2015 Budget \$
6. RESERVES (Continued)		
(i) Environmental Rehabilitation Reserve		
Opening Balance	17,201	17,201
Amount Set Aside / Transfer to Reserve	260	430
Amount Used / Transfer from Reserve	-	-
	<u>17,461</u>	<u>17,631</u>
(j) RTC/PO/NAB Reserve		
Opening Balance	19,476	19,476
Amount Set Aside / Transfer to Reserve	295	487
Amount Used / Transfer from Reserve	-	-
	<u>19,771</u>	<u>19,963</u>
Total Cash Backed Reserves	<u>270,365</u>	<u>376,822</u>
All of the above reserve accounts are supported by money held in financial institutions.		
Summary of Transfers To Cash Backed Reserves		
Transfers to Reserves		
Land and Buildings Reserve	1,407	42,325
Sports Ground Improvement Reserve	39	65
Plant Replacement Reserve	22,191	52,881
Accrued Leave Reserve	188	336
Aged Persons Units Reserve	293	483
Street Light Upgrade Reserve	209	346
Painted Road Reserve	66	101
Industrial Area Development Reserve	72	126
Environmental Rehabilitation Reserve	260	430
RTC/PO/NAB Reserve	295	487
	<u>25,020</u>	<u>97,580</u>
Transfers from Reserves		
Land and Buildings Reserve	(27,319)	0
Sports Ground Improvement Reserve	0	0
Plant Replacement Reserve	(6,578)	0
Accrued Leave Reserve	0	0
Aged Persons Units Reserve	0	0
Street Light Upgrade Reserve	0	0
Painted Road Reserve	0	0
Industrial Area Development Reserve	0	0
Environmental Rehabilitation Reserve	0	0
RTC/PO/NAB Reserve	0	0
	<u>(33,897)</u>	<u>-</u>
Total Transfer to/(from) Reserves	<u>(8,877)</u>	<u>97,580</u>

SHIRE OF MINGENEW
NOTES TO AND FORMING PART OF THE STATEMENT OF FINANCIAL ACTIVITY
FOR THE PERIOD 1 JULY, 2014 TO 28 FEBRUARY, 2015

The budgeted transfers to reserves outlined below have been done in September 2014.

Land & Building Reserve	40,600
Plant Replacement Reserve	50,000

At the Special meeting of Council held on 23 December 2014, amendments were made to reserve transfers as follows:

Transfer to Building Reserve	NIL
Transfer to Plant Reserve	20,000
Transfer from Plant Reserve	20,000
Transfer from Building Reserve	27,319

In accordance with council resolutions in relation to each reserve account, the purpose for which the reserves are set aside are as follows:

Land & Building Reserve

- to be used for the acquisition, construction and maintenance of land and buildings.

Plant Replacement Reserve

- to be used for the purchase of plant.

Accrued Leave Reserve

- to be used to fund annual and long service leave requirements.

Aged Persons' Units Reserve

- to be used for the funding of future operating shortfalls of the aged persons' units in accordance with the management agreement Council has with Homeswest.

Street Light Upgrade Reserve

- to be used for the upgrade of street lights in the town of Mingenew.

Painted Road Reserve

- to be used for the painted road and associated projects.

Industrial Area Development Reserve

- to be used for the development of the industrial area.

Environmental Rehabilitation Reserve

- to be used for the rehabilitation of Gravel Pits.

RTC/PO/NAB Reserve

- to be used for the maintenance and upkeep of the Rural Transaction Centre

None of the above Reserves are expected to be used within a set period as it is envisaged that further transfers to the reserve accounts will occur as funds are utilised.

SHIRE OF MINGENEW
NOTES TO AND FORMING PART OF THE STATEMENT OF FINANCIAL ACTIVITY
FOR THE PERIOD 1 JULY, 2014 TO 28 FEBRUARY, 2015

	28 February, 2015 Actual \$	Brought Forward 1-Jul-14 \$
7. NET CURRENT ASSETS		
Composition of Estimated Net Current Asset Position		
CURRENT ASSETS		
Cash - Unrestricted	238,636	25,543
Cash - Restricted (Reserves)	270,366	279,243
Cash - Restricted (Unspent Grants)	-	-
Cash - Restricted (Unspent Loans)	-	-
Receivables		
- Rates Outstanding	154,573	8,827
- Sundry Debtors	51,888	382,487
- Emergency Services Levy	-	-
- Provision for doubtful debt	(1,370)	(1,370)
- GST Receivable	7,520	46,119
Inventories		
Fuel and Materials	26,319	20,314
Land Held for Resale	40,394	40,394
	<u>788,326</u>	<u>801,557</u>
LESS: CURRENT LIABILITIES		
Payables		
- Sundry Creditors	(304,130)	(367,645)
- GST Payable	(12,877)	(29,631)
- PAYG/Withholding Tax Payable	(9,989)	(11,512)
Accrued Interest/Expenditure	(17,236)	(276,857)
Accrued Salaries & Wages	(15,670)	(15,670)
Loan Liability	(4,492)	(132,611)
Accrued Annual Leave	(123,334)	(123,334)
Accrued LSL	(102,123)	(102,123)
	<u>(589,851)</u>	<u>(1,059,383)</u>
NET CURRENT ASSET POSITION	198,475	(257,826)
Less: Cash - Reserves - Restricted	(270,366)	(279,242)
Land Held for Resale	(40,394)	(40,394)
Add: Loan Liability	4,492	132,611
Provision for Annual Leave	123,334	123,334
Provision for Long Service Leave	102,123	102,123
Less: Cash - Restricted/Committed	<u>-</u>	<u>-</u>
ESTIMATED SURPLUS/(DEFICIENCY) C/FWD	<u>117,664</u>	<u>(219,394)</u>

SHIRE OF MINGENEW
NOTES TO AND FORMING PART OF THE STATEMENT OF FINANCIAL ACTIVITY
FOR THE PERIOD 1 JULY, 2014 TO 28 FEBRUARY, 2015

7.1 Graphical Representation - Liquidity over the Year

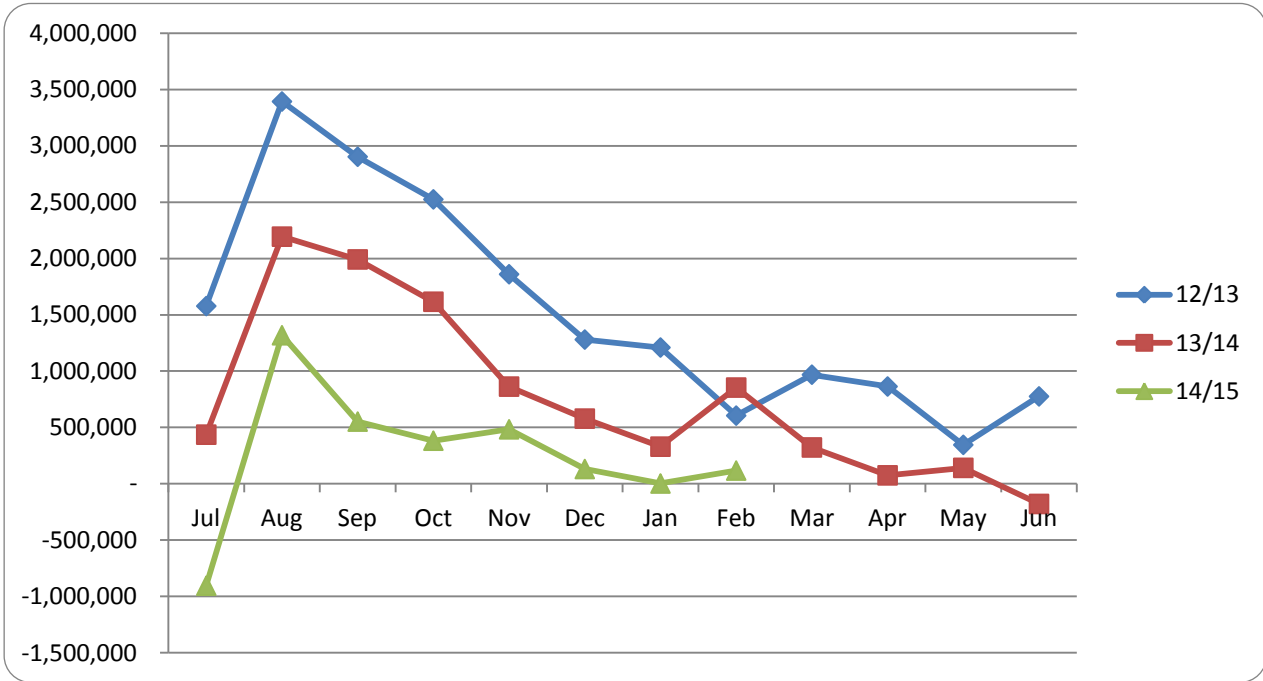

7.2 Graphical Representation - Debtors Outstanding

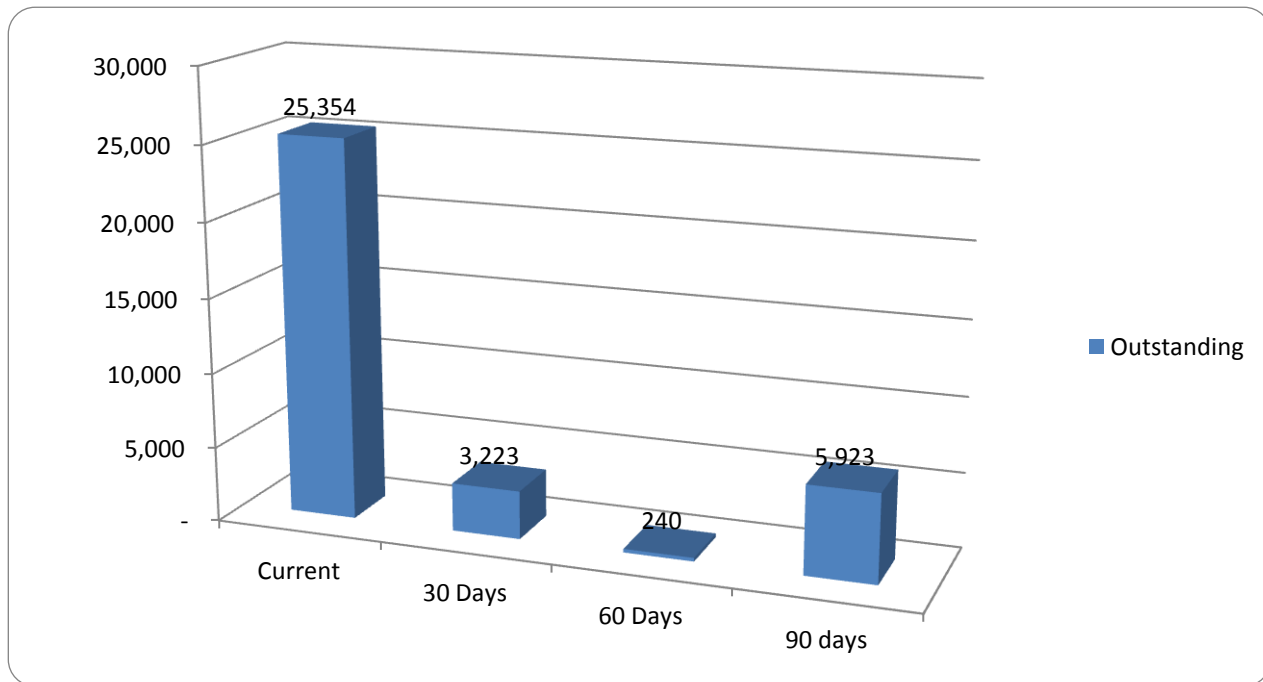

SHIRE OF MINGENEW

NOTES TO AND FORMING PART OF THE STATEMENT OF FINANCIAL ACTIVITY

FOR THE PERIOD 1 JULY, 2014 TO 28 FEBRUARY, 2015

8. RATING INFORMATION - 2014/2015 FINANCIAL YEAR

RATE TYPE	Rate in \$	Number of Properties	Rateable Value \$	2014/2015 Rate Revenue \$	2014/2015 Interim Rates \$	2014/2015 Back Rates \$	2014/2015 Total Revenue \$	2014/2015 Budget \$
General Rate								
GRV - Mingenew Townsite	12.3858	151	1,698,004	210,311	2,790	82	213,183	211,690
GRV -Yandanooka Townsite	6.1988	2	14,716	912	115	0	1,027	912
UV - Rural	1.3510	127	97,543,500	1,317,813	257	4,264	1,322,334	1,321,636
UV - Mining	30.0000	9	63,470	19,041	6,273	15	25,329	19,041
Sub-Totals		289	99,319,690	1,548,077	9,435	4,361	1,561,873	1,553,279
Minimum Rates	Minimum \$							
GRV - Townsites	600	91	108,691	54,600	(1,402)	0	53,198	49,800
GRV -Yandanooka Townsite	320	1	840	320	0	0	320	400
UV - Rural	600	18	473,600	10,800	(320)	0	10,480	6,600
UV - Mining	750	6	7,198	4,500	333	0	4,833	4,500
Sub-Totals		116	590,329	70,220	(1,389)	0	68,831	61,300
Rates Written-Off							(230)	(1,500)
Ex-Gratia Rates							31,601	31,601
Movement in Excess Rates							0	0
Totals							1,662,075	1,646,180

All land except exempt land in the Shire of Mingenew is rated according to its Gross Rental Value (GRV) in townsites or Unimproved Value (UV) in the remainder of the Shire.

The general rates detailed above for the 2014/2015 financial year have been determined by Council on the basis budget and the estimated revenue to be received from all sources of raising the revenue required to meet the deficiency between the total estimated expenditure proposed in the other than rates and also bearing considering the extent of any increase in rating over the level adopted in the previous year.

The minimum rates have been determined by Council on the basis that all ratepayers must make a reasonable contribution to the cost of the Local Government services/facilities.

8.1 Rates Outstanding as at 28th February 2015

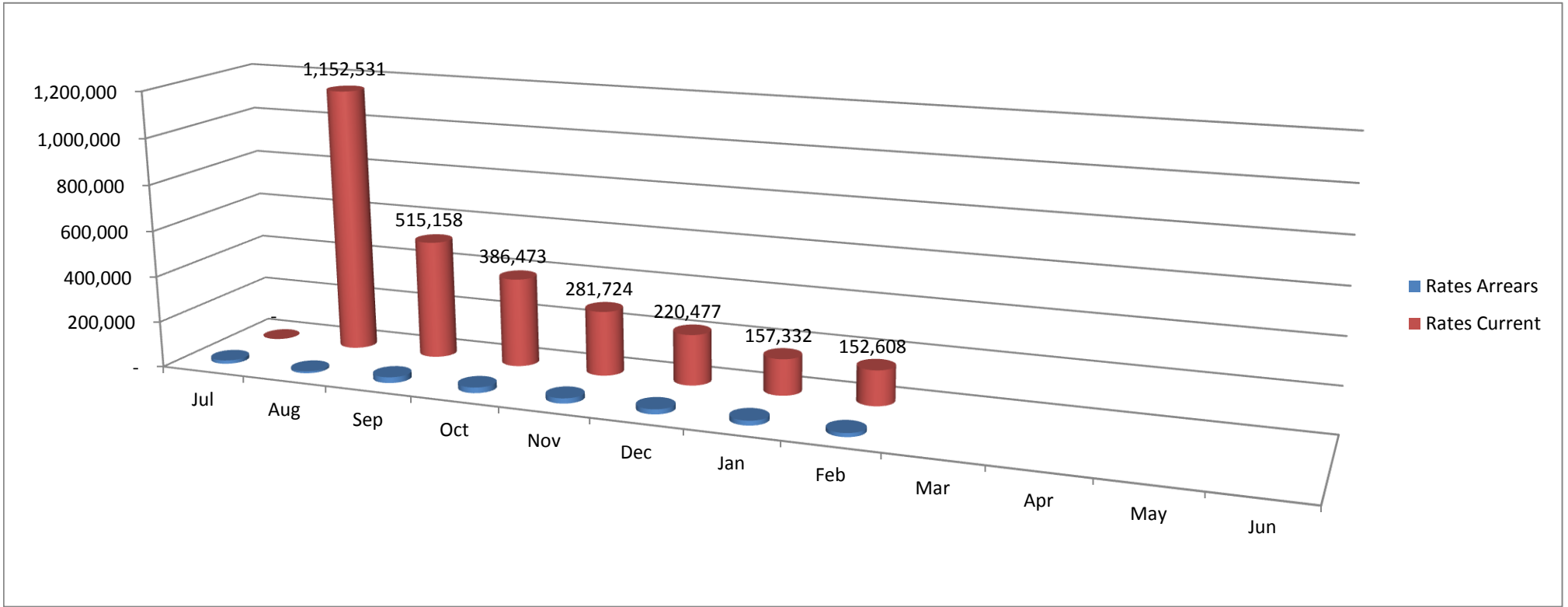

8.2 Sanitation Outstanding as at 28th February 2015

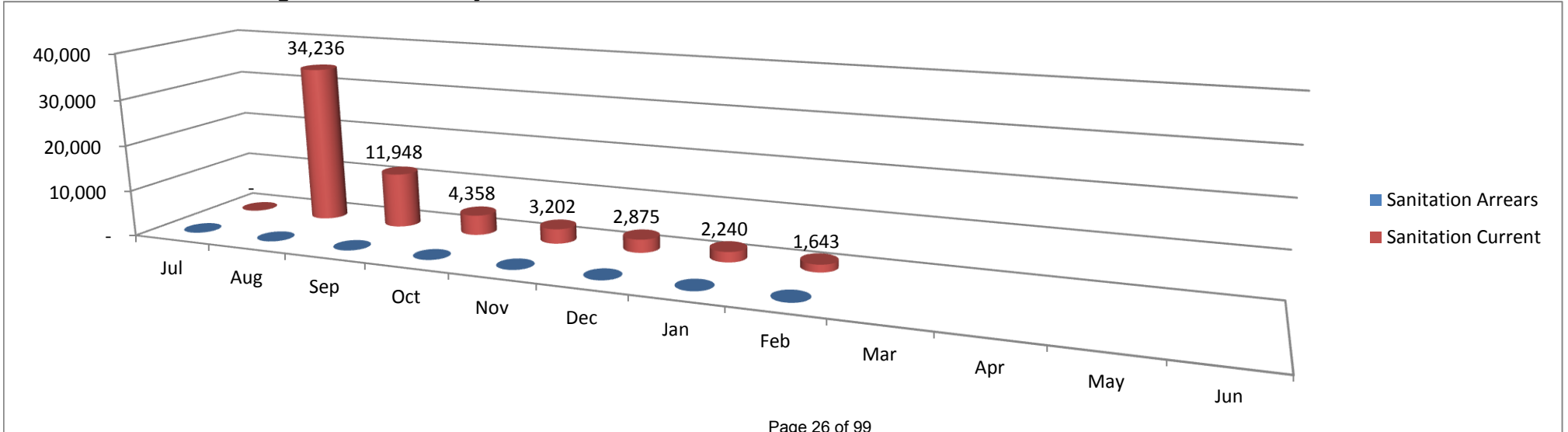

SHIRE OF MINGENEW

NOTES TO AND FORMING PART OF THE STATEMENT OF FINANCIAL ACTIVITY
FOR THE PERIOD 1 JULY, 2014 TO 28 FEBRUARY, 2015

9. TRUST FUNDS

Funds held at balance date over which the Municipality has no control and which are not included in the financial statements are as follows:

Detail	Balance 01-Jul-14 \$	Amounts Received \$	Amounts Paid (\$)	Balance 28-Feb-15 \$
BCITF Levy	241	684	(92)	833
BRB Levy	376	800	(255)	921
Centenary/Autumn Committee	1,734	-	-	1,734
Community Bus	2,060	900	(600)	2,360
ANZAC Day Breakfast Donation	795	-	-	795
Industrial Land Bonds	1,000	-	-	1,000
Mid West Industry Road Safety Alliance	41,371	65,450	(56,677)	50,144
Mingenew Cemetery Group	366	-	-	366
Other Bonds	3,633	513	(300)	3,846
Rec Centre Kitchen Upgrade	2,000	-	-	2,000
Sinosteel Community Trust Fund	63,415	-	-	63,415
Tree Planter - LCDC	288	-	-	288
Weary Dunlop Memorial	1,906	-	-	1,906
Mingenew P & C - NBN Rental	-	5,836	-	5,836
Joan Trust	-	7,600	-	7,600
Youth Advisory Council	1,811	-	-	1,811
	<u>120,996</u>			<u>144,855</u>

10. CASH / INVESTMENTS SUMMARY

Investments

Financial Institution	Fund	Date Invested	Investment Amount \$	Interest Rate %	Maturity Date
Nil					

Cash at Bank

Financial Institution	Fund	Total Cash at Bank
National Australia Bank	Muni	44,484
National Australia Bank	Trust	147,969
National Australia Bank	MWRC Trust	172,087

		Interest	
National Australia Bank	BCM	202,791	2.35%
National Australia Bank	Reserve Maxi	270,366	2.35%

Bank Reconciliations

	MUNICIPAL	TRUST	RESERVES
Bank Statement Balance	44,484	147,969	270,366
Bank Statement Balance - BCM	202,791		
TOTAL Cash as per Bank Statement	<u>247,275</u>	<u>147,969</u>	<u>270,366</u>
General Ledger Balance	238,336	147,929	270,366
Difference	<u>8,939</u>	<u>40</u>	<u>-</u>
Outstanding Deposits	(17,843)		
Outstanding Cheques	26,822		
Credit Card Direct Debit	-		
Transfer between funds	(40)	40	
Explanation for Difference	<u>8,939</u>	<u>40</u>	<u>-</u>

SHIRE OF MINGENEW**INCOME STATEMENT****BY NATURE OR TYPE****FOR THE PERIOD 1 JULY, 2014 TO 28 FEBRUARY, 2015**

	NOTE	28/02/2015 Actual \$	2014 / 2015 Budget \$
REVENUES FROM ORDINARY ACTIVITIES			
Rates	8	1,662,074	1,662,962
Operating Grants, Subsidies and Contributions		763,616	1,032,319
Non-Operating Grants, Subsidies and Contributions		461,371	1,491,586
Profit on Asset Disposals		3,320	4,193
Proceeds on Disposal of Assets		(25)	-
Service Charges		-	-
Fees and Charges		209,396	424,351
Interest Earnings		21,448	33,367
Other Revenue		311,811	438,000
		<u>3,433,011</u>	<u>5,086,778</u>
EXPENSES FROM ORDINARY ACTIVITIES			
Employee Costs		(812,339)	(1,023,655)
Materials and Contracts		(642,990)	(927,390)
Utility Charges		(71,626)	(99,050)
Depreciation		(1,190,681)	(1,454,710)
Loss on Asset Disposals		(8,381)	(11,460)
Interest Expenses		(55,645)	(64,527)
Insurance		(192,139)	(242,782)
Other Expenditure		(342,321)	(528,450)
		<u>(3,316,122)</u>	<u>(4,352,024)</u>
NET RESULT		116,889	734,754

SHIRE OF MINGENEW**INCOME STATEMENT****BY PROGRAM****FOR THE PERIOD 1 JULY, 2014 TO 28 FEBRUARY, 2015**

	28/02/15	28/02/15	2014/15
	Y-T-D Actual	Y-T-D Budget	Total Budget
	\$	\$	\$
OPERATING REVENUES			
Governance	25,093	23,871	27,155
General Purpose Funding	2,128,216	2,125,151	2,272,577
Law, Order, Public Safety	19,293	22,370	27,538
Health	218	217	217
Education and Welfare	66,405	2,708	3,920
Housing	68,168	62,937	93,112
Community Amenities	61,579	59,441	59,964
Recreation and Culture	88,037	82,826	89,685
Transport	866,990	876,380	2,044,888
Economic Services	7,280	7,605	9,843
Other Property and Services	101,731	98,124	116,550
	<u>3,433,010</u>	<u>3,361,630</u>	<u>4,745,449</u>
OPERATING EXPENSES			
Governance	(186,158)	(226,766)	(300,729)
General Purpose Funding	(52,558)	(48,234)	(65,446)
Law, Order, Public Safety	(67,611)	(68,626)	(98,127)
Health	(41,038)	(44,090)	(66,426)
Education and Welfare	(25,505)	(23,174)	(35,957)
Housing	(217,622)	(219,943)	(248,530)
Community Amenities	(94,058)	(99,831)	(163,756)
Recreation & Culture	(704,523)	(629,515)	(853,785)
Transport	(1,704,119)	(1,686,717)	(2,356,757)
Economic Services	(126,134)	(113,239)	(164,240)
Other Property and Services	(96,795)	(91,696)	(111,270)
	<u>(3,316,121)</u>	<u>(3,251,831)</u>	<u>(4,465,023)</u>
NET PROFIT OR LOSS/RESULT	<u>116,889</u>	<u>109,799</u>	<u>280,426</u>

SHIRE OF MINGENEW

BALANCE SHEET

FOR THE PERIOD 1 JULY, 2014 TO 28 FEBRUARY, 2015

	28 February, 2015 ACTUAL \$	2014 \$
CURRENT ASSETS		
Cash and Cash Equivalents	509,002	304,786
Trade and Other Receivables	212,611	436,062
Inventories	26,319	20,314
TOTAL CURRENT ASSETS	<u>747,932</u>	<u>761,162</u>
NON-CURRENT ASSETS		
Other Receivables	-	-
Inventories	90,394	90,394
Property, Plant and Equipment	11,407,335	11,466,124
Infrastructure	37,764,521	37,878,191
TOTAL NON-CURRENT ASSETS	<u>49,262,250</u>	<u>49,434,709</u>
TOTAL ASSETS	<u>50,010,182</u>	<u>50,195,871</u>
CURRENT LIABILITIES		
Trade and Other Payables	356,829	701,315
Long Term Borrowings	4,492	132,611
Provisions	225,457	225,457
TOTAL CURRENT LIABILITIES	<u>586,778</u>	<u>1,059,383</u>
NON-CURRENT LIABILITIES		
Long Term Borrowings	1,075,449	905,449
Provisions	22,381	22,381
TOTAL NON-CURRENT LIABILITIES	<u>1,097,830</u>	<u>927,830</u>
TOTAL LIABILITIES	<u>1,684,608</u>	<u>1,987,213</u>
NET ASSETS	<u>48,325,574</u>	<u>48,208,658</u>
EQUITY		
Retained Profits (Surplus)	28,102,990	27,977,197
Reserves - Cash Backed	270,366	279,243
Reserves - Asset Revaluation	19,952,218	19,952,218
TOTAL EQUITY	<u>48,325,574</u>	<u>48,208,658</u>

SHIRE OF MINGENEW**STATEMENT OF CHANGES IN EQUITY****FOR THE PERIOD 1 JULY, 2014 TO 28 FEBRUARY, 2015**

	28 February 2015 Actual \$	2014 \$
RETAINED PROFITS (SURPLUS)		
Balance as at 1 July 2014	27,977,197	28,186,969
Change in Net Assets Resulting from Operations	116,915	(136,548)
Transfer from/(to) Reserves	<u>8,877</u>	<u>(73,224)</u>
Balance as at 30 June 2015	<u>28,102,989</u>	<u>27,977,197</u>
RESERVES - CASH BACKED		
Balance as at 1 July 2014	279,243	279,243
Amount Transferred (to)/from Surplus	<u>(8,877)</u>	<u>-</u>
Balance as at 30 June 2015	<u>270,366</u>	<u>279,243</u>
RESERVES - ASSET REVALUATION		
Balance as at 1 July 2013	19,952,218	15,239,185
Revaluation Increment	-	4,713,033
Revaluation Decrement	-	-
Balance as at 30 June 2014	<u>19,952,218</u>	<u>19,952,218</u>
TOTAL EQUITY	<u><u>48,325,573</u></u>	<u><u>48,208,658</u></u>

9.2.2 MID WEST REGIONAL COUNCIL – FINANCIAL REPORT FOR PERIOD ENDING 31 MARCH 2014

Location/Address: Shire of Mingenew
Name of Applicant: Shire of Mingenew
Disclosure of Interest: Nil
File Reference: ADM0
Date: 13th March 2015
Author: Nita Jane, Manager Finance & Administration
Senior Officer: Martin Whitely, Chief Executive Officer
Signature of Senior Officer:

Summary

To consider and accept the Mid West Regional Council Financial Report for Period Ending 31st March 2014.

Attachment

Mid West Regional Council Financial Report for Period Ending 31st March 2014.

Background

The Mid West Regional Council was dissolved on 31st March 2014. At the final meeting of the Regional Council the Shire of Mingenew was conferred the responsibility of finalising all outstanding matters of the MWRC through to final audit.

We have been steadily working through the process which has taken longer to complete than anticipated.

Letters were sent to the Shires of Morawa, Three Springs and Perenjori in January 2015 advising them of the progress to date and the anticipated completion of the process.

Comment

The audit of the Financial Report was undertaken by UHY Haines Norton and was completed on 12th March 2015.

Whilst the Mid West Regional Council no longer exists, it would be appropriate for the Shire of Mingenew to receive the final financial report. Following this meeting it is suggested that a copy of the Audited Financial Report be sent to the other MWRC members for their information.

Disbursement of the remaining funds will be undertaken as soon as the costs associated with finalising and auditing of the financial report are received. This is anticipated to be by the end of March 2015.

Consultation

David Tomasi, UHY Haines Norton
 Vern McKay, Department of Local Government
 Martin Whitely

Statutory Environment

Nil

Policy Implications

Nil

Financial Implications

The estimated return to each of the Shires is in the vicinity of \$40,000

Strategic Implications

Nil

Voting Requirements

Simple Majority

OFFICER RECOMMENDATION – ITEM 9.2.2
--

That Council

1. That Council accepts the Mid West Regional Council Financial Report for Period Ending 31st March 2014.
2. That a copy of the audited Financial Report be sent to the Shires of Morawa, Three Springs and Perenjori for their information.
3. That a copy of the audited Financial Report be sent to the Department of Local Government for their information.
4. Following payment of the final invoices relating to preparation and audit of the Financial Report, funds are disbursed to each of the previous members of the MWRC as per the Establishment Agreement.

9 March 2015

The President
Shire of Mingenew (on behalf of Mid West Regional Council)
22 Victoria Street
MINGENEW, WA 6522

16 Lakeside Corporate | 24 Parkland Road
Osborne Park | Perth | WA | 6017
PO Box 1707 | Osborne Park | WA | 6916
t: + 61 8 9444 3400 | f: + 61 8 9444 3430
perth@uhyhn.com.au | www.uhyhn.com



Dear Cr Bagley,

**MID WEST REGIONAL COUNCIL
MANAGEMENT REPORT FOR THE PERIOD ENDED 31 MARCH 2014**

We advise that we have completed our audit procedures for the period ended 31 March 2014 and enclose our Audit Report.

We are required under the Local Government Audit Regulations to report certain compliance matters in our audit report. Other matters which arise during the course of our audit that we wish to bring to Council's attention are raised in this management report.

It should be appreciated that our audit procedures are designed primarily to enable us to form an opinion on the financial statements and therefore may not bring to light all weaknesses in systems and procedures which may exist. However, we aim to use our knowledge of the Regional Council's organisation gained during our work to make comments and suggestions which, we hope, will be useful to you.

COMPLIANCE MATTERS

Whilst we acknowledge the Regional Council was dissolved in accordance with its Establishment Agreement effective from 31 March 2014, for the purpose of completeness, the following items of non-compliance were noted:

- Annual returns of 4 Councilors for the period ended 31 March 2014 contained various sections which had been left blank;
- The delegations register was not reviewed for the financial period ended 31 March 2014 as required by Section 5.46(2) of the Local Government Act; and
- The CEO did not give public notice of the availability of the financial report after the report was accepted by the Regional Council as required by Section 5.55 of the Local Government Act.

We noted no other matters we wish to draw to Council's attention.

UNCORRECTED MISSTATEMENTS

We advise there were no uncorrected misstatements noted during the course of our audit.

We take this opportunity to thank the Manager of Finance and Administration and all staff for the assistance provided during the audit.

Should you wish to discuss any matter relating to the audit or any other matter, please do not hesitate to contact us.

Yours faithfully



DAVID TOMASI
PARTNER

MID WEST REGIONAL COUNCIL
FINANCIAL REPORT
FOR THE PERIOD ENDED 31ST MARCH 2014

TABLE OF CONTENTS

Statement by Chief Executive Officer	2
Statement of Comprehensive Income by Nature or Type	3
Statement of Comprehensive Income by Program	4
Statement of Financial Position	5
Statement of Changes in Equity	6
Statement of Cash Flows	7
Rate Setting Statement	8
Notes to and Forming Part of the Financial Report	9
Independent Audit Report	38
Supplementary Ratio Information	40
Principal place of business: PO Box 3276 Edward Road Geraldton WA 6530	

**MID WEST REGIONAL COUNCIL
FINANCIAL REPORT
FOR THE PERIOD ENDED 31ST MARCH 2014**

**LOCAL GOVERNMENT ACT 1995
LOCAL GOVERNMENT (FINANCIAL MANAGEMENT) REGULATIONS 1996**

STATEMENT BY CHIEF EXECUTIVE OFFICER

The attached financial report of the Mid West Regional Council being the annual financial report and other information for the financial period ended 31 March 2014 are in my opinion properly drawn up to present fairly the financial position of the Mid West Regional Council at 31st March 2014 and the results of the operations for the financial period then ended in accordance with the Australian Accounting Standards and comply with the provisions of the Local Government Act 1995 and the regulations under that Act.

Signed as authorisation of issue on the 12th day of MARCH 2015



Martin Whitely
Chief Executive Officer

**MID WEST REGIONAL COUNCIL
STATEMENT OF COMPREHENSIVE INCOME
BY NATURE OR TYPE
FOR THE PERIOD ENDED 31ST MARCH 2014**

	NOTE	31 March 2014 \$	2014 Budget \$	30 June 2013 \$
Revenue				
Operating Grants, Subsidies and Contributions	22	163,847	780,612	605,269
Fees and Charges	21	143,224	109,500	43,601
Interest Earnings	2(a)	2,805	3,000	4,030
Other Revenue		910,270	1,934,201	1,598,055
		<u>1,220,146</u>	<u>2,827,313</u>	<u>2,250,955</u>
Expenses				
Employee Costs		(172,169)	(258,109)	(270,834)
Materials and Contracts		(167,550)	(641,454)	(370,479)
Depreciation on Non-Current Assets	2(a)	(5,059)	(7,112)	(8,997)
Insurance Expenses		(16,277)	(16,140)	(12,528)
Other Expenditure		(900,408)	(1,950,110)	(1,533,681)
		<u>(1,261,463)</u>	<u>(2,872,925)</u>	<u>(2,196,519)</u>
		(41,317)	(45,612)	54,436
Loss on Asset Disposals	18	<u>(1,959)</u>	<u>0</u>	<u>0</u>
Net Result		(43,276)	(45,612)	54,436
Other Comprehensive Income				
Changes on Revaluation of Non-Current Assets		0	0	0
Total Other Comprehensive Income		<u>0</u>	<u>0</u>	<u>0</u>
Total Comprehensive Income		<u>(43,276)</u>	<u>(45,612)</u>	<u>54,436</u>

This statement is to be read in conjunction with the accompanying notes.

**MID WEST REGIONAL COUNCIL
STATEMENT OF COMPREHENSIVE INCOME
BY PROGRAM
FOR THE PERIOD ENDED 31ST MARCH 2014**

	NOTE	31 March 2014 \$	2014 Budget \$	30 June 2013 \$
Revenue				
Governance		53,929	39,518	42,417
General Purpose Funding		150,000	283,002	145,350
Other Property and Services		1,016,217	2,504,792	2,063,188
	2(a)	<u>1,220,146</u>	<u>2,827,312</u>	<u>2,250,955</u>
Expenses				
Governance		(204,200)	(264,485)	(184,331)
General Purpose Funding		0	0	(2,021)
Other Property and Services		(1,057,263)	(2,608,439)	(2,010,167)
	2(a)	<u>(1,261,463)</u>	<u>(2,872,924)</u>	<u>(2,196,519)</u>
Profit/(Loss) on Disposal of Assets				
Governance		(1,959)	0	0
		<u>(1,959)</u>	<u>0</u>	<u>0</u>
Net Result		<u>(43,276)</u>	<u>(45,612)</u>	<u>54,436</u>
Other Comprehensive Income				
Changes on revaluation of non-current assets		0	0	0
Total Other Comprehensive Income		<u>0</u>	<u>0</u>	<u>0</u>
Total Comprehensive Income		<u><u>(43,276)</u></u>	<u><u>(45,612)</u></u>	<u><u>54,436</u></u>

This statement is to be read in conjunction with the accompanying notes.

**MID WEST REGIONAL COUNCIL
STATEMENT OF FINANCIAL POSITION
FOR THE PERIOD ENDED 31ST MARCH 2014**

	NOTE	31 MARCH 2014 \$	30 JUNE 2013 \$
CURRENT ASSETS			
Cash and Cash Equivalents	3	185,059	236,971
Trade and Other Receivables	4	<u>136,947</u>	<u>267,455</u>
TOTAL CURRENT ASSETS		<u>322,006</u>	<u>504,426</u>
NON-CURRENT ASSETS			
Property, Plant and Equipment	5	<u>0</u>	<u>45,505</u>
TOTAL NON-CURRENT ASSETS		<u>0</u>	<u>45,505</u>
TOTAL ASSETS		<u>322,006</u>	<u>549,931</u>
CURRENT LIABILITIES			
Trade and Other Payables	6	136,942	292,927
Provisions	8	<u>25,870</u>	<u>54,534</u>
TOTAL CURRENT LIABILITIES		<u>162,812</u>	<u>347,461</u>
TOTAL LIABILITIES		<u>162,812</u>	<u>347,461</u>
NET ASSETS		<u>159,194</u>	<u>202,470</u>
EQUITY			
Retained Surplus		159,194	166,091
Reserves - Cash Backed	9	<u>0</u>	<u>36,379</u>
TOTAL EQUITY		<u>159,194</u>	<u>202,470</u>

This statement is to be read in conjunction with the accompanying notes.

**MID WEST REGIONAL COUNCIL
STATEMENT OF CHANGES IN EQUITY
FOR THE PERIOD ENDED 31ST MARCH 2014**

	NOTE	RETAINED SURPLUS \$	RESERVES CASH BACKED \$	REVALUATION SURPLUS \$	TOTAL EQUITY \$
Balance as at 1 July 2012		106,121	41,913	0	148,034
Comprehensive Income					
Net Result		54,436	0	0	54,436
Changes on Revaluation of Non-Current Assets		0	0	0	0
Total Comprehensive Income		<u>54,436</u>	<u>0</u>	<u>0</u>	<u>54,436</u>
Transfers from/(to) Reserves		5,534	(5,534)	0	0
		<u>5,534</u>	<u>(5,534)</u>	<u>0</u>	<u>0</u>
Balance as at 30 June 2013		166,091	36,379	0	202,470
Comprehensive Income					
Net Result		(43,276)	0	0	(43,276)
Changes on Revaluation of Non-Current Assets		0	0	0	0
Total Comprehensive Income		<u>(43,276)</u>	<u>0</u>	<u>0</u>	<u>(43,276)</u>
Transfers from/(to) Reserves		36,379	(36,379)	0	0
		<u>36,379</u>	<u>(36,379)</u>	<u>0</u>	<u>0</u>
Balance as at 31 March 2014		<u>159,194</u>	<u>0</u>	<u>0</u>	<u>159,194</u>

This statement is to be read in conjunction with the accompanying notes.

**MID WEST REGIONAL COUNCIL
STATEMENT OF CASH FLOWS
FOR THE PERIOD ENDED 31ST MARCH 2014**

	NOTE	31 MARCH 2014 \$	2014 Budget \$	30 JUNE 2013 \$
Cash Flows From Operating Activities				
Receipts				
Operating Grants, Subsidies and Contributions		293,373	780,612	544,478
Fees and Charges		143,224	109,500	43,601
Interest Earnings		2,805	3,000	4,030
Goods and Services Tax		135,828	250,000	232,748
Other Revenue		910,270	1,934,200	1,598,061
		<u>1,485,500</u>	<u>3,077,312</u>	<u>2,422,918</u>
Payments				
Employee Costs		(209,517)	(258,109)	(244,780)
Materials and Contracts		(314,851)	(641,454)	(361,189)
Insurance Expenses		(16,277)	(16,140)	(12,528)
Goods and Services Tax		(134,846)	(250,000)	(233,730)
Other Expenditure		(887,963)	(1,950,110)	(1,532,096)
		<u>(1,563,454)</u>	<u>(3,115,813)</u>	<u>(2,384,323)</u>
Net Cash Provided By (Used In) Operating Activities	10(b)	<u>(77,954)</u>	<u>(38,501)</u>	<u>38,595</u>
Cash Flows from Investing Activities				
Payments for Purchase of Property, Plant & Equipment		(322)	(4,000)	(15,340)
Proceeds from Sale of Fixed Assets		26,364	0	0
Net Cash Provided by (Used in) Investment Activities		<u>26,042</u>	<u>(4,000)</u>	<u>(15,340)</u>
Net Increase (Decrease) in Cash Held		(51,912)	(42,501)	23,255
Cash at Beginning of Year		236,971	82,379	213,716
Cash and Cash Equivalents at the End of the Year	10(a)	<u><u>185,059</u></u>	<u><u>39,878</u></u>	<u><u>236,971</u></u>

This statement is to be read in conjunction with the accompanying notes.

**MID WEST REGIONAL COUNCIL
RATE SETTING STATEMENT
FOR THE PERIOD ENDED 31ST MARCH 2014**

	NOTE	31 MARCH 2014 \$	2014 Budget \$	30 JUNE 2013 \$
Revenue				
Governance		53,929	39,518	42,417
General Purpose Funding		150,000	283,002	145,350
Other Property and Services		<u>1,016,217</u>	<u>2,504,792</u>	<u>2,063,188</u>
		1,220,146	2,827,312	2,250,955
Expenses				
Governance		(206,159)	(264,485)	(184,331)
General Purpose Funding		0	0	(2,021)
Other Property and Services		<u>(1,057,263)</u>	<u>(2,608,439)</u>	<u>(2,010,167)</u>
		(1,263,422)	(2,872,924)	(2,196,519)
Net Result Excluding Rates		(43,276)	(45,612)	54,436
Adjustments for Cash Budget Requirements:				
(Profit)/Loss on Asset Disposals	18	1,959	0	0
Loss on Revaluation of Assets		10,289	0	1,585
Movement in Employee Benefit Provisions (Non-current)		6,377	0	(5,534)
Write off Furniture & Equipment Assets		2,156	0	0
Depreciation and Amortisation on Assets	2(a)	5,059	7,112	8,997
Capital Expenditure and Revenue				
Purchase Furniture and Equipment	5(a)	0	(4,000)	(15,340)
Purchase Plant and Equipment	5(a)	(322)	0	0
Proceeds from Disposal of Fixed Assets	18	26,364	0	0
Transfers to Reserves (Restricted Assets)	9	(11,084)	(2,500)	0
Transfers from Reserves (Restricted Assets)	9	47,463	45,000	5,534
ADD Estimated Surplus/(Deficit) July 1 B/Fwd	20(b)	140,079	0	90,401
LESS Estimated Surplus/(Deficit) June 30 C/Fwd	20(b)	185,064	0	140,079
Total Amount Raised from General Rate	20(a)	<u><u>0</u></u>	<u><u>0</u></u>	<u><u>0</u></u>

This statement is to be read in conjunction with the accompanying notes.

**MID WEST REGIONAL COUNCIL
NOTES TO AND FORMING PART OF THE FINANCIAL REPORT
FOR THE PERIOD ENDED 31ST MARCH 2014**

1. SUMMARY OF SIGNIFICANT ACCOUNTING POLICIES

(a) Basis of Preparation

The financial report comprises general purpose financial statements which have been prepared in accordance with Australian Accounting Standards (as they apply to local governments and not-for-profit entities), Australian Accounting Interpretations, other authoritative pronouncements of the Australian Accounting Standards Board, the Local Government Act 1995 and accompanying regulations. Material accounting policies which have been adopted in the preparation of this financial report are presented below and have been consistently applied unless stated otherwise.

Except for cash flow and rate setting information, the report has also been prepared on the accrual basis and is based on historical costs, modified, where applicable, by the measurement at fair value of selected non-current assets, financial assets and liabilities.

Critical Accounting Estimates

The preparation of a financial report in conformity with Australian Accounting Standards requires management to make judgements, estimates and assumptions that effect the application of policies and reported amounts of assets and liabilities, income and expenses.

The estimates and associated assumptions are based on historical experience and various other factors that are believed to be reasonable under the circumstances; the results of which form the basis of making the judgements about carrying values of assets and liabilities that are not readily apparent from other sources. Actual results may differ from these estimates.

Going Concern

Due to the withdrawal of all the participating members, the Regional Council decided to cease its activities on 31 March 2014. Plant and Equipment assets have been disposed of as per note 5a. Last of the Furniture and Equipment assets have been written off as they cannot be disposed. A provision for dissolution expenses is included in the financial report at 31 March 2014. Assets exceed liabilities at this date and on winding up of this entity any surplus funds will be divided among the participating members. Equally, any liabilities are born equally amongst the participating members.

The Local Government Reporting Entity

All Funds through which the Council controls resources to carry on its functions have been included in the financial statements forming part of this financial report.

In the process of reporting on the local government as a single unit, all transactions and balances between those Funds (for example, loans and transfers between Funds) have been eliminated.

All monies held in the Trust Fund are excluded from the financial statements. A separate statement of those monies appears at Note 16 to these financial statements.

(b) Goods and Services Tax (GST)

Revenues, expenses and assets are recognised net of the amount of GST, except where the amount of GST incurred is not recoverable from the Australian Taxation Office (ATO).

Receivables and payables are stated inclusive of GST receivable or payable.

The net amount of GST recoverable from, or payable to, the ATO is included with receivables or payables in the statement of financial position.

Cash flows are presented on a gross basis. The GST components of cash flows arising from investing or financing activities which are recoverable from, or payable to, the ATO are presented as operating cash flows.

(c) Cash and Cash Equivalents

Cash and cash equivalents include cash on hand, cash at bank, deposits available on demand with banks and other short term highly liquid investments that are readily convertible to known amounts of cash and which are subject to an insignificant risk of changes in value and bank overdrafts.

Bank overdrafts are reported as short term borrowings in current liabilities in the statement of financial position.

**MID WEST REGIONAL COUNCIL
NOTES TO AND FORMING PART OF THE FINANCIAL REPORT
FOR THE PERIOD ENDED 31ST MARCH 2014**

1. SUMMARY OF SIGNIFICANT ACCOUNTING POLICIES (Continued)

(d) Trade and Other Receivables

Trade and other receivables include amounts due from ratepayers for unpaid rates and service charges and other amounts due from third parties for goods sold and services performed in the ordinary course of business.

Receivables expected to be collected within 12 months of the end of the reporting period are classified as current assets. All other receivables are classified as non-current assets.

Collectability of trade and other receivables is reviewed on an ongoing basis. Debts that are known to be uncollectible are written off when identified. An allowance for doubtful debts is raised when there is objective evidence that they will not be collectible.

(e) Fixed Assets

Each class of fixed assets within either property, plant and equipment or infrastructure, is carried at cost or fair value as indicated less, where applicable, any accumulated depreciation and impairment losses.

Mandatory Requirement to Revalue Non-Current Assets

Effective from 1 July 2012, the Local Government (Financial Management) Regulations were amended and the measurement of non-current assets at Fair Value became mandatory.

The amendments allow for a phasing in of fair value in relation to fixed assets over three years as follows:

- (a) for the financial year ending on 30 June 2013, the fair value of all of the assets of the local government that are plant and equipment; and
- (b) for the financial year ending on 30 June 2014, the fair value of all of the assets of the local government -
 - (i) that are plant and equipment; and
 - (ii) that are -
 - (I) land and buildings; or-
 - (II) Infrastructure;
- and
- (c) for a financial year ending on or after 30 June 2015, the fair value of all of the assets of the local government.

Thereafter, in accordance with the regulations, each asset class must be revalued at least every 3 years.

In 2013, Council commenced the process of adopting Fair Value in accordance with the Regulations.

Relevant disclosures, in accordance with the requirements of Australian Accounting Standards, have been made in the financial report as necessary.

**MID WEST REGIONAL COUNCIL
NOTES TO AND FORMING PART OF THE FINANCIAL REPORT
FOR THE PERIOD ENDED 31ST MARCH 2014**

1. SUMMARY OF SIGNIFICANT ACCOUNTING POLICIES (Continued)

(e) Fixed Assets (Continued)

Initial Recognition and Measurement between Mandatory Revaluation Dates

All assets are initially recognised at cost and subsequently revalued in accordance with the mandatory measurement framework detailed above.

In relation to this initial measurement, cost is determined as the fair value of the assets given as consideration plus costs incidental to the acquisition. For assets acquired at no cost or for nominal consideration, cost is determined as fair value at the date of acquisition. The cost of non-current assets constructed by the Council includes the cost of all materials used in construction, direct labour on the project and an appropriate proportion of variable and fixed overheads.

Individual assets acquired between initial recognition and the next revaluation of the asset class in accordance with the mandatory measurement framework detailed above, are carried at cost less accumulated depreciation as management believes this approximates fair value. They will be subject to subsequent revaluation at the next anniversary date in accordance with the mandatory measurement framework detailed above.

Revaluation

Increases in the carrying amount arising on revaluation of assets are credited to a revaluation surplus in equity. Decreases that offset previous increases of the same asset are recognised against revaluation surplus directly in equity. All other decreases are recognised in profit or loss.

Transitional Arrangements

During the time it takes to transition the carrying value of non-current assets from the cost approach to the fair value approach, the Council may still be utilising both methods across differing asset classes.

Those assets carried at cost will be carried in accordance with the policy detailed in the ***Initial Recognition*** section as detailed above.

Those assets carried at fair value will be carried in accordance with the ***Revaluation*** Methodology section as detailed above.

Early Adoption of AASB 13 - Fair Value Measurement

Whilst the new accounting standard in relation to Fair Value, AASB 13 – Fair Value Measurement only become applicable for the year ended 30 June 2014 (in relation to Council), given the legislative need to commence using Fair Value methodology in the previous reporting period (year ended 30 June 2013) the Council chose to early adopt AASB 13 (as allowed for in the standard).

As a consequence, the principles embodied in *AASB 13 - Fair Value Measurement* have been applied to the previous reporting period (year ended 30 June 2013).

Land Under Roads

In Western Australia, all land under roads is Crown Land, the responsibility for managing which, is vested in the local government.

Effective as at 1 July 2008, Council elected not to recognise any value for land under roads acquired on or before 30 June 2008. This accords with the treatment available in Australian Accounting Standard AASB 1051 Land Under Roads and the fact Local Government (Financial Management) Regulation 16(a)(i) prohibits local governments from recognising such land as an asset.

In respect of land under roads acquired on or after 1 July 2008, as detailed above, Local Government (Financial Management) Regulation 16(a)(i) prohibits local governments from recognising such land as an asset.

Whilst such treatment is inconsistent with the requirements of AASB 1051, Local Government (Financial Management) Regulation 4(2) provides, in the event of such an inconsistency, the Local Government (Financial Management) Regulations prevail.

Consequently, any land under roads acquired on or after 1 July 2008 is not included as an asset of the Council.

**MID WEST REGIONAL COUNCIL
NOTES TO AND FORMING PART OF THE FINANCIAL REPORT
FOR THE PERIOD ENDED 31ST MARCH 2014**

1. SUMMARY OF SIGNIFICANT ACCOUNTING POLICIES (Continued)

(e) Fixed Assets (Continued)

Depreciation

The depreciable amount of all fixed assets including buildings but excluding freehold land, are depreciated on a straight-line basis over the individual asset's useful life from the time the asset is held ready for use. Leasehold improvements are depreciated over the shorter of either the unexpired period of the lease or the estimated useful life of the improvements.

When an item of property, plant and equipment is revalued, any accumulated depreciation at the date of the revaluation is treated in one of the following ways:

- a) Restated proportionately with the change in the gross carrying amount of the asset so that the carrying amount of the asset after revaluation equals its revalued amount; or
- b) Eliminated against the gross carrying amount of the asset and the net amount restated to the revalued amount of the asset.

Major depreciation periods used for each class of depreciable asset are:

Furniture and Equipment	4 to 10 years
Plant and Equipment	5 to 15 years

The assets residual values and useful lives are reviewed, and adjusted if appropriate, at the end of each reporting period.

An asset's carrying amount is written down immediately to its recoverable amount if the asset's carrying amount is greater than its estimated recoverable amount.

Gains and losses on disposals are determined by comparing proceeds with the carrying amount. These gains and losses are included in the statement of comprehensive income in the period in which they arise.

When revalued assets are disposed of, amounts included in the revaluation surplus relating to that asset are transferred to retained surplus.

Capitalisation Threshold

Expenditure on items of equipment under \$2,000 is not capitalised. Rather, it is recorded on an asset inventory listing.

(f) Fair Value of Assets and Liabilities

When performing a revaluation, the Council uses a mix of both independent and management valuations using the following as a guide:

Fair Value is the price that Council would receive to sell the asset or would have to pay to transfer a liability, in an orderly (i.e. unforced) transaction between independent, knowledgeable and willing market participants at the measurement date.

As fair value is a market-based measure, the closest equivalent observable market pricing information is used to determine fair value. Adjustments to market values may be made having regard to the characteristics of the specific asset. The fair values of assets that are not traded in an active market are determined using one or more valuation techniques. These valuation techniques maximise, to the extent possible, the use of observable market data.

To the extent possible, market information is extracted from either the principal market for the asset (i.e. the market with the greatest volume and level of activity for the asset or, in the absence of such a market, the most advantageous market available to the entity at the end of the reporting period (i.e. the market that maximises the receipts from the sale of the asset after taking into account transaction costs and transport costs).

For non-financial assets, the fair value measurement also takes into account a market participant's ability to use the asset in its highest and best use or to sell it to another market participant that would use the asset in its highest and best use.

**MID WEST REGIONAL COUNCIL
NOTES TO AND FORMING PART OF THE FINANCIAL REPORT
FOR THE PERIOD ENDED 31ST MARCH 2014**

1. SUMMARY OF SIGNIFICANT ACCOUNTING POLICIES (Continued)

(f) Fair Value of Assets and Liabilities (continued)

Fair Value Hierarchy

AASB 13 requires the disclosure of fair value information by level of the fair value hierarchy, which categorises fair value measurement into one of three possible levels based on the lowest level that an input that is significant to the measurement can be categorised into as follows:

Level 1

Measurements based on quoted prices (unadjusted) in active markets for identical assets or liabilities that the entity can access at the measurement date.

Level 2

Measurements based on inputs other than quoted prices included in Level 1 that are observable for the asset or liability, either directly or indirectly.

Level 3

Measurements based on unobservable inputs for the asset or liability.

The fair values of assets and liabilities that are not traded in an active market are determined using one or more valuation techniques. These valuation techniques maximise, to the extent possible, the use of observable market data. If all significant inputs required to measure fair value are observable, the asset or liability is included in Level 2. If one or more significant inputs are not based on observable market data, the asset or liability is included in Level 3.

Valuation techniques

The Council selects a valuation technique that is appropriate in the circumstances and for which sufficient data is available to measure fair value. The availability of sufficient and relevant data primarily depends on the specific characteristics of the asset or liability being measured. The valuation techniques selected by the Council are consistent with one or more of the following valuation approaches:

Market approach

Valuation techniques that use prices and other relevant information generated by market transactions for identical or similar assets or liabilities.

Income approach

Valuation techniques that convert estimated future cash flows or income and expenses into a single discounted present value.

Cost approach

Valuation techniques that reflect the current replacement cost of an asset at its current service capacity.

Each valuation technique requires inputs that reflect the assumptions that buyers and sellers would use when pricing the asset or liability, including assumptions about risks. When selecting a valuation technique, the Council gives priority to those techniques that maximise the use of observable inputs and minimise the use of unobservable inputs. Inputs that are developed using market data (such as publicly available information on actual transactions) and reflect the assumptions that buyers and sellers would generally use when pricing the asset or liability and considered observable, whereas inputs for which market data is not available and therefore are developed using the best information available about such assumptions are considered unobservable.

As detailed above, the mandatory measurement framework imposed by the Local Government (Financial Management) Regulations requires, as a minimum, all assets carried at a revalued amount to be revalued at least every 3 years.

**MID WEST REGIONAL COUNCIL
NOTES TO AND FORMING PART OF THE FINANCIAL REPORT
FOR THE PERIOD ENDED 31ST MARCH 2014**

1. SUMMARY OF SIGNIFICANT ACCOUNTING POLICIES (Continued)

(g) Impairment of Assets

In accordance with Australian Accounting Standards the Council's assets, other than inventories, are assessed at each reporting date to determine whether there is any indication they may be impaired.

Where such an indication exists, an impairment test is carried out on the asset by comparing the recoverable amount of the asset, being the higher of the asset's fair value less costs to sell and value in use, to the asset's carrying amount.

Any excess of the asset's carrying amount over its recoverable amount is recognised immediately in profit or loss, unless the asset is carried at a revalued amount in accordance with another standard (e.g. AASB 116) whereby any impairment loss of a revalued asset is treated as a revaluation decrease in accordance with that other standard.

For non-cash generating assets such as roads, drains, public buildings and the like, value in use is represented by the depreciated replacement cost of the asset.

(h) Trade and Other Payables

Trade and other payables represent liabilities for goods and services provided to the Council prior to the end of the financial year that are unpaid and arise when the Council becomes obliged to make future payments in respect of the purchase of these goods and services. The amounts are unsecured, are recognised as a current liability and are normally paid within 30 days of recognition.

(i) Employee Benefits

Short-Term Employee Benefits

Provision is made for the Council's obligations for short-term employee benefits. Short-term employee benefits are benefits (other than termination benefits) that are expected to be settled wholly before 12 months after the end of the annual reporting period in which the employees render the related service, including wages, salaries and sick leave. Short-term employee benefits are measured at the (undiscounted) amounts expected to be paid when the obligation is settled.

The Council's obligations for short-term employee benefits such as wages, salaries and sick leave are recognised as a part of current trade and other payables in the statement of financial position. The Council's obligations for employees' annual leave and long service leave entitlements are recognised as provisions in the statement of financial position.

Other Long-Term Employee Benefits

Provision is made for employees' long service leave and annual leave entitlements not expected to be settled wholly within 12 months after the end of the annual reporting period in which the employees render the related service. Other long-term employee benefits are measured at the present value of the expected future payments to be made to employees. Expected future payments incorporate anticipated future wage and salary levels, durations or service and employee departures and are discounted at rates determined by reference to market yields at the end of the reporting period on government bonds that have maturity dates that approximate the terms of the obligations. Any remeasurements for changes in assumptions of obligations for other long-term employee benefits are recognised in profit or loss in the periods in which the changes occur.

The Council's obligations for long-term employee benefits are presented as non-current provisions in its statement of financial position, except where the Council does not have an unconditional right to defer settlement for at least 12 months after the end of the reporting period, in which case the obligations are presented as current provisions.

**MID WEST REGIONAL COUNCIL
NOTES TO AND FORMING PART OF THE FINANCIAL REPORT
FOR THE PERIOD 31ST MARCH 2014**

1. SUMMARY OF SIGNIFICANT ACCOUNTING POLICIES (Continued)

(j) Borrowing Costs

Borrowing costs are recognised as an expense when incurred except where they are directly attributable to the acquisition, construction or production of a qualifying asset. Where this is the case, they are capitalised as part of the cost of the particular asset until such time as the asset is substantially ready for its intended use or sale.

(k) Provisions

Provisions are recognised when the Council has a present legal or constructive obligation, as a result of past events, for which it is probable that an outflow of economic benefits will result and that outflow can be reliably measured.

Provisions are measured using the best estimate of the amounts required to settle the obligation at the end of the reporting period.

(l) Leases

Leases of fixed assets where substantially all the risks and benefits incidental to the ownership of the asset, but not legal ownership, are transferred to the Council, are classified as finance leases.

Finance leases are capitalised recording an asset and a liability at the lower amounts equal to the fair value of the leased property or the present value of the minimum lease payments, including any guaranteed residual values. Lease payments are allocated between the reduction of the lease liability and the lease interest expense for the period.

Leased assets are depreciated on a straight line basis over the shorter of their estimated useful lives or the lease term.

Lease payments for operating leases, where substantially all the risks and benefits remain with the lessor, are charged as expenses in the periods in which they are incurred.

Lease incentives under operating leases are recognised as a liability and amortised on a straight line basis over the life of the lease term.

(m) Rates, Grants, Donations and Other Contributions

Rates, grants, donations and other contributions are recognised as revenues when the local government obtains control over the assets comprising the contributions.

Control over assets acquired from rates is obtained at the commencement of the rating period or, where earlier, upon receipt of the rates.

Where contributions recognised as revenues during the reporting period were obtained on the condition that they be expended in a particular manner or used over a particular period, and those conditions were undischarged as at the reporting date, the nature of and amounts pertaining to 'those undischarged conditions are disclosed in Note 2(c). That note also discloses the amount of contributions recognised as revenues in a previous reporting period which were obtained in respect of the local government's operations for the current reporting period.

**MID WEST REGIONAL COUNCIL
NOTES TO AND FORMING PART OF THE FINANCIAL REPORT
FOR THE PERIOD 31ST MARCH 2014**

1. SUMMARY OF SIGNIFICANT ACCOUNTING POLICIES (Continued)

(n) Superannuation

The Council contributes to a number of Superannuation Funds on behalf of employees. All funds to which the Council contributes are defined contribution plans.

(o) Current and Non-Current Classification

In the determination of whether an asset or liability is current or non-current, consideration is given to the time when each asset or liability is expected to be settled. The asset or liability is classified as current if it is expected to be settled within the next 12 months, being the Council's operational cycle. In the case of liabilities where the Council does not have the unconditional right to defer settlement beyond 12 months, such as vested long service leave, the liability is classified as current even if not expected to be settled within the next 12 months. Inventories held for trading are classified as current even if not expected to be realised in the next 12 months except for land held for sale where it is held as non-current based on the Council's intentions to release for sale.

(p) Rounding Off Figures

All figures shown in this annual financial report, other than a rate in the dollar, are rounded to the nearest dollar.

(q) Comparative Figures

Where required, comparative figures have been adjusted to conform with changes in presentation for the current financial year.

When the Council applies an accounting policy retrospectively, makes a retrospective restatement or reclassifies items in its financial statement, an additional (third) statement of financial position as at the beginning of the preceding period in addition to the minimum comparative financial statements is presented.

(r) Budget Comparative Figures

Unless otherwise stated, the budget comparative figures shown in this annual financial report relate to the original budget estimate for the relevant item of disclosure.

(s) Dissolution

During the ordinary council meeting of the Mid West Regional Council held on 4th February 2014, the Council resolved unanimously to dissolve the Regional Council as at 31st March 2014.

MID WEST REGIONAL COUNCIL
NOTES TO AND FORMING PART OF THE FINANCIAL REPORT
FOR THE PERIOD ENDED 31ST MARCH 2014

1. SIGNIFICANT ACCOUNTING POLICIES (Continued)**(t) New Accounting Standards and Interpretations for Application in Future Periods**

The AASB has issued a number of new and amended Accounting Standards and Interpretations that have mandatory application dates for future reporting periods, some of which are relevant to the Council.

Management's assessment of the new and amended pronouncements that are relevant to the Council, applicable to future reporting periods and which have not yet been adopted are set out as follows:

Title	Issued / Compiled	Applicable ⁽¹⁾	Impact
(i) AASB 9 – Financial Instruments	December 2013	1 January 2018	Nil – The objective of this Standard is to improve and simplify the approach for classification and measurement of financial assets compared with the requirements of AASB 139. Given the nature of the financial assets of the Council, it is not anticipated the standard will have any material effect.
(ii) AASB 2010 -7 Amendments to Australian Accounting Standards arising from AASB 9 (December 2010)	December 2013	1 January 2018	Nil - The revisions embodied in this standard give effect to the consequential changes arising from the issuance of AASB 9 which is not anticipated to have any material effect on the Council (refer (i) above).
[AASB 1, 3, 4, 5, 7, 101, 102, 108, 112, 118, 120, 121, 127, 128, 131, 132, 136, 137, 139, 1023 & 1038 and Interpretations 2, 5, 10, 12, 19 & 127]			

MID WEST REGIONAL COUNCIL
NOTES TO AND FORMING PART OF THE FINANCIAL REPORT
FOR THE PERIOD ENDED 31ST MARCH 2014

1. SIGNIFICANT ACCOUNTING POLICIES (Continued)**(t) New Accounting Standards and Interpretations for Application in Future Periods (Continued)**

Title	Issued / Compiled	Applicable ⁽¹⁾	Impact
(iii) AASB 2011 - 7 Amendments to Australian Accounting Standards arising from the Consolidation and Joint Arrangement Standards [Not-For-Profit entities] [AASB 1, 3, 5, 7, 9, 2009-11, 101, 107, 112, 118, 121, 124, 131, 132, 133, 138, 139, 1023 & 1038 and Interpretations 5, 9, 16 & 17]	December 2012	1 January 2014	Consequential changes to various standards arising from the issuance of AASB 10, 11, 12, 127 and 128. It is not expected to have a significant impact on Council.
(iv) AASB 2012-3: Amendments to Australian Accounting Standards - Offsetting Financial Assets and Financial Liabilities [AASB 132]	June 2012	1 January 2014	This Standard adds application guidance to AASB 132: Financial Instruments: Presentation to address potential inconsistencies identified in applying some of the offsetting criteria of AASB 132, including clarifying the meaning of “currently has a legally enforceable right of set-off” and that some gross settlement systems may be considered equivalent to net settlement. This Standard is not expected to significantly impact the Council’s financial statements.

MID WEST REGIONAL COUNCIL
NOTES TO AND FORMING PART OF THE FINANCIAL REPORT
FOR THE PERIOD ENDED 31ST MARCH 2014

1. SIGNIFICANT ACCOUNTING POLICIES (Continued)**(t) New Accounting Standards and Interpretations for Application in Future Periods (Continued)**

Title	Issued / Compiled	Applicable ⁽¹⁾	Impact
(v) AASB 2013 - 3: Amendments to AASB 136 - Recoverable Amount Disclosures for Non-Financial Assets	June 2013	1 January 2014	<p>This standard makes amendments to AASB 136 and includes requirements to disclose additional information when present value techniques are used to measure the recoverable amount of impaired assets.</p> <p>It is not expected to have a significant impact on Council.</p>
(vi) AASB 2013-8: Amendments to Australian Accounting Standards – Australian Implementation Guidance for Not-for-Profit Entities – Control and Structured Entities [AASB 10, 12 & 1049]	October 2013	1 January 2014	<p>This standard adds Appendix E to AASB 10 to provide implementation guidance for Not-for-Profit entities regarding control criteria from the perspective of not-for-profit entities.</p> <p>It is not expected to have a significant impact on Council.</p>
(vii) AASB 2013-9: Amendments to Australian Accounting Standards – Conceptual Framework, Materiality and Financial Instruments [Operative dates: Part A Conceptual Framework – 20 December 2013; Part B Materiality – 1 January 2014; Part C Financial Instruments – 1 January 2015]	December 2013	Refer Title column	<p>Part A of this standard makes various editorial corrections to Australian Accounting Standards.</p> <p>Part B of this standard deletes references to AASB 1031 in various Australian Accounting Standards in advance of the withdrawal of AASB 1031.</p> <p>Part C of this standard makes consequential amendments to AASB 9 and numerous other standards and amends the permissions around certain applications relating to financial liabilities reissued at fair value.</p> <p>As the bulk of changes related either to editorial or reference changes it is not expected to have a significant impact on Council.</p>

Notes:

⁽¹⁾ Applicable to reporting periods commencing on or after the given date.

MID WEST REGIONAL COUNCIL**NOTES TO AND FORMING PART OF THE FINANCIAL REPORT
FOR THE PERIOD ENDED 31ST MARCH 2014****1. SIGNIFICANT ACCOUNTING POLICIES (Continued)****(u) Adoption of New and Revised Accounting Standards**

During the current year, the Council adopted all of the new and revised Australian Accounting Standards and Interpretations which were compiled, became mandatory and which were applicable to its operations.

These new and revised standards were:

AASB 10	AASB 128	AASB 2012 - 2
AASB 11	AASB 2011 - 7	AASB 2012 - 3
AASB 12	AASB 2011 - 9	AASB 2012 - 5
AASB 119	AASB 2011 - 10	AASB 2012 - 10
AASB 127		

Most of the standards adopted had a minimal effect on the accounting and reporting practices of the Council as they did not have a significant impact on the accounting or reporting practices or were either not applicable, largely editorial in nature, were revisions to help ensure consistency with presentation, recognition and measurement criteria of IFRSs or related to topics not relevant to operations.

**MID WEST REGIONAL COUNCIL
NOTES TO AND FORMING PART OF THE FINANCIAL REPORT
FOR THE PERIOD ENDED 31ST MARCH 2014**

2. REVENUE AND EXPENSES	31 MARCH 2014 \$	30 JUNE 2013 \$
(a) Net Result		
The Net Result includes:		
(i) Charging as an Expense:		
Auditors Remuneration		
- Audit of the annual financial report	7,000	6,000
Depreciation		
Furniture and Equipment	3,059	3,885
Plant and Equipment	2,000	5,112
	5,059	8,997
Rental Charges		
- Operating Leases	6,852	8,375
	6,852	8,375
(ii) Crediting as Revenue:		
Other Revenue		
Reimbursements and Recoveries	910,270	12,269
Other	0	1,585,786
	910,270	1,598,055
	31 MARCH 2014 \$	30 JUNE 2013 \$
Interest Earnings		
Other Interest Revenue	2,805	4,030
	2,805	4,030

(b) Statement of Objective

The Mid West Regional Council is dedicated to providing high quality services to the communities of the Shires of Mingenew, Morawa, Perenjori and Three Springs through the various service orientated programs which it has established.

Council operations as disclosed in these financial statements encompass the following service orientated activities/programs.

GOVERNANCE

Members of the Mid West Regional Council, Auditing, Reporting to Councils.

GENERAL PURPOSE FUNDING

General purpose government grants and interest revenue.

OTHER PROPERTY AND SERVICES

Service delivery units including Finance
MWLGSA - agreement with Main Roads

**MID WEST REGIONAL COUNCIL
NOTES TO AND FORMING PART OF THE FINANCIAL REPORT
FOR THE PERIOD ENDED 31ST MARCH 2014**

2. REVENUE AND EXPENSES (Continued)

(c) Conditions Over Grants/Contributions

<u>Grant/Contribution</u>	<u>Function/ Activity</u>	<u>Opening Balance ⁽¹⁾ 1/07/12 \$</u>	<u>Received ⁽²⁾ 2012/13 \$</u>	<u>Expended ⁽³⁾ 2012/13 \$</u>	<u>Closing Balance ⁽¹⁾ 30/06/13 \$</u>	<u>Received ⁽²⁾ 2013/14 \$</u>	<u>Expended ⁽³⁾ 2013/14 \$</u>	<u>Closing Balance 31/03/14 \$</u>
Baler Project - Waste Management	OP &S	40,000	0	(40,000)	0	0	0	0
Total		<u><u>40,000</u></u>	<u><u>0</u></u>	<u><u>(40,000)</u></u>	<u><u>0</u></u>	<u><u>0</u></u>	<u><u>0</u></u>	<u><u>0</u></u>

Notes:

(1) - Grants/contributions recognised as revenue in a previous reporting period which were not expended at the close of the previous reporting period.

(2) - New grants/contributions which were recognised as revenues during the reporting period and which had not yet been fully expended in the manner specified by the contributor.

(3) - Grants/contributions which had been recognised as revenues in a previous reporting period or received in the current reporting period and which were expended in the current reporting period in the manner specified by the contributor.

**MID WEST REGIONAL COUNCIL
NOTES TO AND FORMING PART OF THE FINANCIAL REPORT
FOR THE PERIOD ENDED 31ST MARCH 2014**

	Note	31 MARCH 2014 \$	30 JUNE 2013 \$
3. CASH AND CASH EQUIVALENTS			
Unrestricted		185,059	200,592
Restricted		<u>0</u>	<u>36,379</u>
		<u><u>185,059</u></u>	<u><u>236,971</u></u>
The following restrictions have been imposed by regulations or other externally imposed requirements:			
Leave Reserve	9	0	19,493
Plant & Equipment Reserve	9	<u>0</u>	<u>16,886</u>
		<u><u>0</u></u>	<u><u>36,379</u></u>
4. TRADE AND OTHER RECEIVABLES			
Current			
Sundry Debtors		136,947	266,473
GST Receivable		<u>0</u>	<u>982</u>
		<u><u>136,947</u></u>	<u><u>267,455</u></u>
		31 MARCH 2014 \$	30 JUNE 2013 \$
5. PROPERTY, PLANT AND EQUIPMENT			
Furniture and Equipment at:			
Management Valuation 2014		0	0
- Cost		0	29,539
Less Accumulated Depreciation		<u>0</u>	<u>(14,034)</u>
		<u><u>0</u></u>	<u><u>15,505</u></u>
Plant and Equipment at:			
- Management Valuation 2013		<u>0</u>	<u>30,000</u>
		<u><u>0</u></u>	<u><u>30,000</u></u>
		<u><u>0</u></u>	<u><u>45,505</u></u>

Plant and Equipment:

The Council's plant and equipment were revalued at 30 June 2013 by management. All of the valuations were made on the basis of open market values of similar assets adjusted for condition and comparability (Level 2 inputs in the fair value hierarchy).

Furniture and Equipment

The Council's furniture and equipment were revalued at 31 March 2014 by management. All of the valuations were made on the basis of open market values of similar assets adjusted for condition and comparability (Level 2 inputs in the fair value hierarchy).

**MID WEST REGIONAL COUNCIL
NOTES TO AND FORMING PART OF THE FINANCIAL REPORT
FOR THE PERIOD ENDED 31ST MARCH 2014**

5. PROPERTY, PLANT AND EQUIPMENT (Continued)

(a) Movements in Carrying Amounts

Movement in the carrying amounts of each class of property, plant and equipment between the beginning and the end of the current financial year.

		Balance at the Beginning of the Year	Additions	(Disposals)	Revaluation Increments/ (Decrements)	Impairment (Losses)/ Reversals	Depreciation (Expense)	Carrying Amount at the End of Year
		\$	\$	\$	\$	\$	\$	\$
Furniture and Equipment	(Level 2)	15,505	0	0	(10,290)	(2,156)	(3,059)	0
Plant and Equipment	(Level 2)	30,000	322	(28,322)	0	0	(2,000)	0
Total Property, Plant and Equipment		<u>45,505</u>	<u>322</u>	<u>(28,322)</u>	<u>(10,290)</u>	<u>(2,156)</u>	<u>(5,059)</u>	<u>0</u>

**MID WEST REGIONAL COUNCIL
NOTES TO AND FORMING PART OF THE FINANCIAL REPORT
FOR THE PERIOD ENDED 31ST MARCH 2014**

	31 MARCH 2014 \$	30 JUNE 2013 \$
6. TRADE AND OTHER PAYABLES		
Current		
Sundry Creditors	105,230	263,811
Accrued Salaries and Wages	0	11,908
ATO Liabilities	3,224	0
Accrued Expenditure	16,616	770
Payroll Liabilities	11,872	16,438
	<u>136,942</u>	<u>292,927</u>

7. LONG-TERM BORROWINGS

The Mid West Regional Council did not have any long term borrowings at the reporting date.

	31 MARCH 2014 \$	30 JUNE 2013 \$
8. PROVISIONS		
Analysis of Total Provisions		
Current		
	<u>25,870</u>	<u>54,534</u>
	<u>25,870</u>	<u>54,534</u>

	Provision for Dissolution Expenses \$	Provision for Annual Leave \$	Provision for Long Service Leave \$	Total \$
Opening balance at 1 July 2013	0	27,929	26,605	54,534
Additional provision	25,870	0	0	25,870
Amounts used	0	(27,929)	(26,605)	(54,534)
Balance at 31 March 2014	<u>25,870</u>	<u>0</u>	<u>0</u>	<u>25,870</u>

**MID WEST REGIONAL COUNCIL
NOTES TO AND FORMING PART OF THE FINANCIAL REPORT
FOR THE PERIOD ENDED 31ST MARCH 2014**

	31 MARCH 2014 \$	2014 Budget \$	30 JUNE 2013 \$
9. RESERVES - CASH BACKED			
(a) Leave Reserve			
Opening Balance	19,493	19,493	25,027
Amount Set Aside / Transfer to Reserve	11,084	2,500	0
Amount Used / Transfer from Reserve	<u>(30,577)</u>	<u>(15,000)</u>	<u>(5,534)</u>
	<u>0</u>	<u>6,993</u>	<u>19,493</u>
(b) Plant & Equipment Reserve			
Opening Balance	16,886	16,886	16,886
Amount Set Aside / Transfer to Reserve	0	0	0
Amount Used / Transfer from Reserve	<u>(16,886)</u>	<u>0</u>	<u>0</u>
	<u>0</u>	<u>16,886</u>	<u>16,886</u>
(c) Unspent Grants & Contributions Reserve			
Opening Balance	0	30,000	0
Amount Set Aside / Transfer to Reserve	0	0	0
Amount Used / Transfer from Reserve	<u>0</u>	<u>(30,000)</u>	<u>0</u>
	<u>0</u>	<u>0</u>	<u>0</u>
TOTAL RESERVES	<u>0</u>	<u>23,879</u>	<u>36,379</u>
Total Opening Balance	36,379	66,379	41,913
Total Amount Set Aside / Transfer to Reserve	11,084	2,500	0
Total Amount Used / Transfer from Reserve	<u>(47,463)</u>	<u>(45,000)</u>	<u>(5,534)</u>
TOTAL RESERVES	<u>0</u>	<u>23,879</u>	<u>36,379</u>

All of the reserve accounts are supported by money held in financial institutions and match the amount shown as restricted cash in Note 3 to this financial report.

In accordance with council resolutions in relation to each reserve account, the purpose for which the funds are set aside are as follows:

- (a) Leave Reserve**
- to be used to fund annual and long service leave requirements
- (b) Plant & Equipment Reserve**
- to be used for the purchase or replacement of items of plant and equipment (vehicles, office equipment etc)
- (c) Unspent Grants & Contributions Reserve**
- to be used to quarantine unspent grants and contributions for future use.

All funds held in reserve have been transferred to the Municipal fund as part of the dissolution process and form part of the funds distributed to the members.

**MID WEST REGIONAL COUNCIL
NOTES TO AND FORMING PART OF THE FINANCIAL REPORT
FOR THE PERIOD ENDED 31ST MARCH 2014**

10. NOTES TO THE STATEMENT OF CASH FLOWS

(a) Reconciliation of Cash

For the purposes of the Statement of Cash Flows, cash includes cash and cash equivalents, net of outstanding bank overdrafts. Cash at the end of the reporting period is reconciled to the related items in the Statement of Financial Position as follows:

	31 MARCH 2014 \$	2014 Budget \$	30 JUNE 2013 \$
Cash and Cash Equivalents	<u>185,059</u>	<u>39,878</u>	<u>236,971</u>

(b) Reconciliation of Net Cash Provided By Operating Activities to Net Result

Net Result	(43,276)	(45,612)	54,436
Depreciation	5,059	(7,112)	8,997
(Profit)/Loss on Sale of Asset	1,959	0	0
(Increase)/Decrease in Receivables	130,508	8,000	(61,773)
(Increase)/Decrease in Inventories	0	0	0
Increase/(Decrease) in Payables	(155,985)	6,223	27,755
Increase/(Decrease) in Provisions	(28,664)	0	2,568
Increase/(Decrease) in Prepayments	0	0	6
Increase/(Decrease) in Accrued Wages	0	0	7,048
Increase/(Decrease) in Accrued Expenditure	0	0	(9,428)
Write off Furniture & Equipment Assets	2,156	0	0
Increase/(Decrease) in ATO Liabilities	0	0	(9,037)
Increase/(Decrease) in Payroll Liabilities	0	0	16,438
Loss on Revaluation of Fixed Assets	10,289	0	1,585
Net Cash from Operating Activities	<u>(77,954)</u>	<u>(38,501)</u>	<u>38,595</u>

**(c) Undrawn Borrowing Facilities
Credit Standby Arrangements**

	2014 \$	2013 \$
Credit Card limit	0	6,000
Credit Card Balance at Balance Date	<u>0</u>	<u>368</u>
Total Amount of Credit Unused	<u>0</u>	<u>6,368</u>

**MID WEST REGIONAL COUNCIL
NOTES TO AND FORMING PART OF THE FINANCIAL REPORT
FOR THE PERIOD ENDED 31ST MARCH 2014**

11. CONTINGENT LIABILITIES

There are no known contingent liabilities at balance date.

12. CAPITAL AND LEASING COMMITMENTS	31 MARCH 2014 \$	30 JUNE 2013 \$
(a) Operating Lease Commitments		
Non-cancellable operating leases contracted for but not capitalised in the accounts.		
Payable:		
- not later than one year	0	9,137
- later than one year but not later than five years	0	19,035
	<u>0</u>	<u>19,035</u>
	<u>0</u>	<u>28,172</u>

The Council did not have any future operating lease commitments at the reporting date.

(b) Capital Expenditure Commitments

The Mid West Regional Council did not have any future capital expenditure commitments at the reporting date.

13. JOINT VENTURE ARRANGEMENTS

The Mid West Regional Council is not involved in any joint venture arrangements.

14. TOTAL ASSETS CLASSIFIED BY FUNCTION AND ACTIVITY

	31 MARCH 2014 \$	30 JUNE 2013 \$
Governance	19,596	93,950
Other Property and Services	119,507	266,473
Unallocated	182,903	189,508
	<u>322,006</u>	<u>549,931</u>

15. SUBSEQUENT EVENTS

As outlined in Note 1(a) Basis of Preparation - Going Concern - an ordinary meeting of the Mid West Regional Council held on 4 February 2014 unanimously resolved to dissolve the Regional Council as at 31 March 2014 and outlined the process for this to occur. As at March 2015, most of the liabilities have been paid and most of the receivables have been receipted. On finalisation of the audit and other matters any surplus funds will be distributed among participating members.

**MID WEST REGIONAL COUNCIL
NOTES TO AND FORMING PART OF THE FINANCIAL REPORT
FOR THE PERIOD ENDED 31ST MARCH 2014**

	31 MARCH 2014	30 JUNE 2013	30 JUNE 2012
16. FINANCIAL RATIOS			
Current Ratio	1.978	1.427	1.176
Asset Sustainability Ratio	0.064	1.710	0.490
Debt Service Cover Ratio	N/A*	N/A*	N/A*
Operating Surplus Ratio	(0.041)	0.029	(0.061)
Own Source Revenue Coverage Ratio	0.836	0.860	0.905

The above ratios are calculated as follows:

Current Ratio	$\frac{\text{current assets minus restricted assets}}{\text{current liabilities minus liabilities associated with restricted assets}}$
Asset Sustainability Ratio	$\frac{\text{capital renewal and replacement expenditure}}{\text{Depreciation expenses}}$
Debt Service Cover Ratio	$\frac{\text{annual operating surplus before interest and depreciation}}{\text{principal and interest}}$
Operating Surplus Ratio	$\frac{\text{operating revenue minus operating expenses}}{\text{own source operating revenue}}$
Own Source Revenue Coverage Ratio	$\frac{\text{own source operating revenue}}{\text{operating expenses}}$

Notes:

Information relating to the **Asset Consumption Ratio** and the **Asset Renewal Funding Ratio** can be found at Supplementary Ratio Information on Page 40 of this document.

*N/A due to the Council having no borrowings.

**MID WEST REGIONAL COUNCIL
NOTES TO AND FORMING PART OF THE FINANCIAL REPORT
FOR THE PERIOD ENDED 31ST MARCH 2014**

17. TRUST FUNDS

Funds held at balance date over which the Shire has no control and which are not included in the financial statements are as follows:

	Balance 1 July 2013 \$	Amounts Received \$	Amounts Paid (\$)	Balance 31 March 2014 \$
Dry Season Reference Group	8,516	0	(8,516)	0
	8,516			0

18. DISPOSALS OF ASSETS - 2013/14 FINANCIAL YEAR

The following assets were disposed of during the year.

	Net Book Value		Sale Price		Profit (Loss)	
	Actual \$	Budget \$	Actual \$	Budget \$	Actual \$	Budget \$
Plant and Equipment						
<u>Governance</u>						
MWRC1	28,323	0	26,364	0	(1,959)	0
	28,323	0	26,364	0	(1,959)	0
					0	0
					(1,959)	0
					(1,959)	0

**MID WEST REGIONAL COUNCIL
NOTES TO AND FORMING PART OF THE FINANCIAL REPORT
FOR THE PERIOD ENDED 31ST MARCH 2014**

19. INFORMATION ON BORROWINGS

(a) Repayments - Debentures

Mid West Regional Council did not have any borrowings.

(b) New Debentures - 2013/14

The Mid West Regional Council did not take up any new debentures during the period ended 31 March 2014.

(c) Unspent Debentures

The Mid West Regional Council did not have any unspent debentures as at 31 March 2014.

(d) Overdraft

Council did not utilise any overdraft facility during the period.

20. RATING INFORMATION - 2013/14 FINANCIAL YEAR

(a) Being a Regional Council, no rates were raised during the period ended 31 March 2014.

**MID WEST REGIONAL COUNCIL
NOTES TO AND FORMING PART OF THE FINANCIAL REPORT
FOR THE PERIOD ENDED 31ST MARCH 2014**

20. RATING INFORMATION - 2013/14 FINANCIAL YEAR (Continued)

(b) Information on Surplus/(Deficit) Brought Forward

	2014 (31 March 2014 Carried Forward) \$	2014 (1 July 2013 Brought Forward) \$	2013 (30 June 2013 Carried Forward) \$
Surplus/(Deficit) 1 July 13 Brought Forward	<u>185,064</u>	<u>140,079</u>	<u>140,079</u>
<u>Comprises:</u>			
Cash and Cash Equivalents			
Unrestricted	185,059	200,592	200,592
Restricted	0	36,379	36,379
Receivables			
Sundry Debtors	136,947	266,473	266,473
GST Receivable	0	982	982
<u>Less:</u>			
Trade and other Payables			
Sundry Creditors	(117,102)	(280,249)	(280,249)
Accrued Salaries and Wages	0	(11,908)	(11,908)
ATO Liabilities	(3,224)	0	0
Accrued Expenditure	(16,616)	(770)	(770)
Provisions			
Provision for Expenses post dissolution	(25,870)	0	0
Provision for Long Service Leave	0	(35,041)	(35,041)
<u>Net Current Assets</u>	<u>159,194</u>	<u>176,458</u>	<u>176,458</u>
Less:			
Reserves - Restricted Cash	0	(36,379)	(36,379)
Add:			
Provision for Expenses post dissolution	25,870	0	0
Surplus/(Deficit)	<u>185,064</u>	<u>140,079</u>	<u>140,079</u>

Difference

There was no difference between the Surplus/(Deficit) 1 July 2013 Brought Forward position used in the 2014 audited financial report and the Surplus/(Deficit) Carried Forward position as disclosed in the 2013 audited financial report.

MID WEST REGIONAL COUNCIL
NOTES TO AND FORMING PART OF THE FINANCIAL REPORT
FOR THE PERIOD ENDED 31ST MARCH 2014

21. FEES & CHARGES	31 MARCH 2014 \$	30 JUNE 2013 \$
Governance	33,262	0
Other Property and Services	109,962	43,601
	<u>143,224</u>	<u>43,601</u>

There were no changes during the year to the amount of the fees or charges detailed in the original budget.

22. GRANT REVENUE

Grants, subsidies and contributions are included as operating revenues in the Statement of Comprehensive Income:

By Nature or Type:	31 MARCH 2014 \$	30 JUNE 2013 \$
Operating Grants, Subsidies and Contributions	163,847	605,269
	<u>163,847</u>	<u>605,269</u>
By Program:		
Governance	151,131	159,144
General Purpose Funding	0	446,125
Other Property and Services	12,716	0
	<u>163,847</u>	<u>605,269</u>

23. EMPLOYEE NUMBERS

The number of full-time equivalent employees at balance date

<u>3</u>	<u>3</u>
----------	----------

24. ELECTED MEMBERS REMUNERATION

The following fees, expenses and allowances were paid to council members and/or the president.

	31 MARCH 2014 \$	2014 Budget \$	30 JUNE 2013 \$
Meeting Fees	4,328	7,160	2,520
Chairman's Allowance	1,600	1,000	600
Deputy Chairman's Allowance	400	250	150
Travelling Expenses	725	1,500	312
	<u>7,053</u>	<u>9,910</u>	<u>3,582</u>

25. MAJOR LAND TRANSACTIONS

No major land transactions occurred during the period ended 31 March 2014.

26. TRADING UNDERTAKINGS AND MAJOR TRADING UNDERTAKINGS

Council did not participate in any trading undertakings or major trading undertakings during the period ended 31 March 2014.

**MID WEST REGIONAL COUNCIL
NOTES TO AND FORMING PART OF THE FINANCIAL REPORT
FOR THE PERIOD ENDED 31ST MARCH 2014**

27. FINANCIAL RISK MANAGEMENT

Council's activities expose it to a variety of financial risks including price risk, credit risk, liquidity risk and interest rate risk. The Council's overall risk management focuses on the unpredictability of financial markets and seeks to minimise potential adverse effects on the financial performance of the Council.

Council does not engage in transactions expressed in foreign currencies and is therefore not subject to foreign currency risk.

Financial risk management is carried out by the finance area under policies approved by the Council.

The Council held the following financial instruments at balance date:

	Carrying Value		Fair Value	
	2014	2013	2014	2013
	\$	\$	\$	\$
Financial Assets				
Cash and cash equivalents	185,059	236,971	185,059	236,971
Receivables	136,947	267,455	136,947	267,455
	<u>322,006</u>	<u>504,426</u>	<u>322,006</u>	<u>504,426</u>
Financial Liabilities				
Payables	136,942	292,927	136,942	292,927
	<u>136,942</u>	<u>292,927</u>	<u>136,942</u>	<u>292,927</u>

Fair value is determined as follows:

- Cash and Cash Equivalents, Receivables, Payables - estimated to the carrying value which approximates net market value.

**MID WEST REGIONAL COUNCIL
NOTES TO AND FORMING PART OF THE FINANCIAL REPORT
FOR THE PERIOD ENDED 31ST MARCH 2014**

27. FINANCIAL RISK MANAGEMENT (Continued)

(a) Cash and Cash Equivalents

Council's objective is to maximise its return on cash and investments whilst maintaining an adequate level of liquidity and preserving capital. The finance area manages the cash and investments portfolio with the assistance of independent advisers (where applicable). Council has an investment policy and the policy is subject to review by Council. An Investment Report is provided to Council on a monthly basis setting out the make-up and performance of the portfolio.

Cash is subject to interest rate risk - the risk that movements in interest rates could affect returns.

Another risk associated with cash is credit risk – the risk that a contracting entity will not complete its obligations under a financial instrument resulting in a financial loss to Council.

Council manages these risks by only investing with recognised Australian banks.

	2014	2013
	\$	\$
Impact of a 1% ⁽¹⁾ movement in interest rates on cash		
- Equity	2,186	2,433
- Statement of Comprehensive Income	2,186 ⁽²⁾	2,433 ^(*)

Notes:

⁽¹⁾ Sensitivity percentages based on management's expectation of future possible market movements.

⁽²⁾ Maximum impact.

**MID WEST REGIONAL COUNCIL
NOTES TO AND FORMING PART OF THE FINANCIAL REPORT
FOR THE PERIOD ENDED 31ST MARCH 2014**

27. FINANCIAL RISK MANAGEMENT (Continued)
(b) Receivables

Council's major receivables comprise rates and annual charges and user charges and fees. The major risk associated with these receivables is credit risk – the risk that the debts may not be repaid. Council manages this risk by monitoring outstanding debt and employing debt recovery policies.

The level of outstanding receivables is reported to Council monthly and benchmarks are set and monitored for acceptable collection performance.

Council makes suitable provision for doubtful receivables as required and carries out credit checks on most non-rate debtors.

There are no material receivables that have been subject to a re-negotiation of repayment terms.

The profile of the Council's credit risk at balance date was:

	2014	2013
Percentage of Other Receivables		
- Current	89%	72%
- Overdue	11%	28%

**MID WEST REGIONAL COUNCIL
NOTES TO AND FORMING PART OF THE FINANCIAL REPORT
FOR THE PERIOD ENDED 31ST MARCH 2014**

27. FINANCIAL RISK MANAGEMENT (Continued)

(c) Payables

Borrowings

Payables and borrowings are both subject to liquidity risk – that is the risk that insufficient funds may be on hand to meet payment obligations as and when they fall due. Council manages this risk by monitoring its cash flow requirements and liquidity levels and maintaining an adequate cash buffer. Payment terms can be extended and overdraft facilities drawn upon if required.

The contractual undiscounted cash flows of Council's Payables and Borrowings are set out in the Liquidity Sensitivity Table below:

	Due within 1 year \$	Due between 1 & 5 years \$	Due after 5 years \$	Total contractual cash flows \$	Carrying values \$
<u>2014</u>					
Payables	136,942	0	0	136,942	136,942
	<u>136,942</u>	<u>0</u>	<u>0</u>	<u>136,942</u>	<u>136,942</u>
<u>2013</u>					
Payables	292,927	0	0	292,927	292,927
	<u>292,927</u>	<u>0</u>	<u>0</u>	<u>292,927</u>	<u>292,927</u>

INDEPENDENT AUDITOR'S REPORT TO THE MEMBERS OF THE MID WEST REGIONAL COUNCIL

REPORT ON THE FINANCIAL REPORT

We have audited the accompanying financial report of the Mid West Regional Council, which comprises the statement of financial position as at 31 March 2014, statement of comprehensive income by nature or type, statement of comprehensive income by program, statement of changes in equity, statement of cash flows and the rate setting statement for the period then ended, notes comprising a summary of significant accounting policies and other explanatory information and the statement by Chief Executive Officer.

MANAGEMENT'S RESPONSIBILITY FOR THE FINANCIAL REPORT

Management is responsible for the preparation of the financial report that gives a true and fair view in accordance with Australian Accounting Standards, the Local Government Act 1995 (as amended) and the Local Government (Financial Management) Regulations 1996 (as amended) and for such internal control as management determines is necessary to enable the preparation of the financial report that is free from material misstatement, whether due to fraud or error.

AUDITOR'S RESPONSIBILITY

Our responsibility is to express an opinion on the financial report based on our audit. We conducted our audit in accordance with Australian Auditing Standards. These Auditing Standards require that we comply with relevant ethical requirements relating to audit engagements and plan and perform the audit to obtain reasonable assurance about whether the financial report is free from material misstatement.

An audit involves performing procedures to obtain audit evidence about the amounts and disclosures in the financial report. The procedures selected depend on the auditor's judgement, including the assessment of the risks of material misstatement of the financial report, whether due to fraud or error. In making those risk assessments, the auditor considers internal control relevant to the Council's preparation of the financial report that gives a true and fair view in order to design audit procedures that are appropriate in the circumstances, but not for the purpose of expressing an opinion on the effectiveness of the Council's internal control. An audit also includes evaluating the appropriateness of accounting policies used and the reasonableness of accounting estimates made by the Regional Council, as well as evaluating the overall presentation of the financial report.

We believe the audit evidence we obtained is sufficient and appropriate to provide a basis for our audit opinion.

AUDITOR'S OPINION

In our opinion, the financial report of the Mid West Regional Council is in accordance with the Local Government Act 1995 (as amended) and the Local Government (Financial Management) Regulations 1996 (as amended), including:

- a. giving a true and fair view of the Regional Council's financial position as at 31 March 2014 and of its performance for the period ended on that date; and
- b. complying with Australian Accounting Standards, the Local Government Act 1995 (as amended) and the Local Government (Financial Management) Regulations 1996 (as amended).

**INDEPENDENT AUDITOR'S REPORT
TO THE MEMBERS OF THE MID WEST REGIONAL COUNCIL (CONTINUED)**

OTHER MATTER

We draw attention to Note 1(a) of the financial report which indicates that the Mid West Regional Council has been dissolved effective 31 March 2014 and states the basis on which the financial statements have been prepared.

REPORT ON OTHER LEGAL AND REGULATORY REQUIREMENTS

In accordance with the Local Government (Audit) Regulations 1996, we also report that:

- a) There are no matters that in our opinion indicate significant adverse trends in the financial position or the financial management practices of the Council. We note the Regional Council has been dissolved effective 31 March 2014 as mentioned above.
- b) No other matters indicating non-compliance with Part 6 of the Local Government Act 1995 (as amended), the Local Government (Financial Management) Regulations 1996 (as amended) or applicable financial controls of any other written law were noted during the course of our audit.
- c) In relation to the Supplementary Ratio Information presented at page 40 of this report, we have reviewed the calculation for the Asset Consumption Ratio as presented and nothing has come to our attention to suggest it is not:
 - i) reasonably calculated; and
 - ii) based on verifiable information

The Asset Renewal Funding Ratio was not calculated and hence no review was carried out.

- d) All necessary information and explanations were obtained by us.
- e) All audit procedures were satisfactorily completed in conducting our audit.

UHY HAINES NORTON
CHARTERED ACCOUNTANTS



DAVID TOMASI
PARTNER

Date: 12 March 2015
Perth, WA

**MID WEST REGIONAL COUNCIL
SUPPLEMENTARY RATIO INFORMATION
FOR THE PERIOD ENDED 31ST MARCH 2014**

RATIO INFORMATION

The following information relates to those ratios which only require attestation they have been checked and are supported by verifiable information. It does not form part of the audited financial report.

	31 MARCH 2014	30 JUNE 2013	30 JUNE 2012
Asset Consumption Ratio	0.00	0.99	N/A
Asset Renewal Funding Ratio	N/A*	N/A*	N/A

The above ratios are calculated as follows:

Asset Consumption Ratio	$\frac{\text{depreciated replacement costs of assets}}{\text{current replacement cost of depreciable assets}}$
Asset Renewal Funding Ratio	$\frac{\text{NPV of planning capital renewal over 10 years}}{\text{NPV of required capital expenditure over 10 years}}$

N/A - In keeping with amendments to Local Government (Financial Management) Regulations 50, comparatives for the two preceeding years (being 2012 and 2011) have not been reported as financial information is not available.

N/A* - Council is unable to provide an Asset Renewal Funding Ratio at this time as the information required is not available.

9.2.3 ACCOUNTS FOR PAYMENT – MONTH ENDING 28TH FEBRUARY 2015
--

Location/Address: Shire of Mingenew
Name of Applicant: Shire of Mingenew
File Reference: ADM0042
Disclosure of Interest: Nil
Date: 10th March 2015
Author: Julie Borrett, Senior Finance Officer
Senior Officer: Nita Jane, Manager of Administration and Finance

Summary

Council to confirm the payment of creditors for the month of February 2015 in accordance with the Local Government (Financial Management) Regulations 1996 section 13(1).

Attachment

Copy of list of accounts due (EFT & cheque payments), which will enable Council to confirm the payment of its creditors in accordance with Local Government (Financial Management) Regulations 1996, Section 13(1).

Background

Financial Regulations require a schedule of payments made through the Council bank accounts to be presented to Council for their inspection. The list includes details for each account paid incorporating the payee's name, amount of payment, date of payment and sufficient information to identify the transaction.

Comment

Invoices supporting all payments are available for inspection. All invoices and vouchers presented to Council have been certified as to the receipt of goods and the rendition of services and as to prices, computations and costings, and that the amounts shown were due for payment.

Consultation

Nil

Statutory Environment

Local Government Act 1996, Section 6.4

Local Government (Financial Management) Regulations 1996, Sections 12, 13 and 15

Policy Implications

Payments have been made under delegation.

Financial Implications

Funds available to meet expenditure.

Strategic Implications

Nil

Voting Requirements

Simple Majority

OFFICER RECOMMENDATION – ITEM 9.2.3

That Council confirm the accounts as presented for February 2015 from the Municipal Fund totalling \$227,747.29 represented by Electronic Funds Transfers of EFT 8745 to EFT8809, Direct Deduction DD7044.1, 2 and 3, DD7060.1 2 and 3, Trust Cheque number 444 and Cheque numbers 7945-7949.

Date: 09/03/2015
Time: 12:27:44PM

Shire of MINGENEW
List of accounts for February 2015

USER: SFO
PAGE: 1

Cheque /EFT No	Date	Name	Invoice Description	Bank Code	INV Amount	Amount
444	23/02/2015	MINGENEW SHIRE COUNCIL	MWIRSA REFUND CP85	T		2,200.00
7945	02/02/2015	MINGENEW SHIRE COUNCIL	Payroll deductions	M		290.00
7946	09/02/2015	TELSTRA	CHARGES	M		1,746.61
7947	16/02/2015	MINGENEW SHIRE COUNCIL	Payroll deductions	M		290.00
7948	16/02/2015	WATER CORPORATION	WATER	M		8,193.53
7949	23/02/2015	SYNERGY	CHARGES	M		2,640.60
EFT8745	02/02/2015	RSM BIRD CAMERON	CHARGES	M		1,072.50
EFT8746	02/02/2015	DONGARA CARPET CLEANERS	CHARGES	M		400.00
EFT8747	02/02/2015	Great Northern Rural Services	FERTILISER	M		740.00
EFT8748	02/02/2015	MIDWEST MOBILE MECHANICS	CHARGES	M		730.05
EFT8749	02/02/2015	MIDWEST AERO MEDICAL AIR AMBULANCE P/L	FEES	M		500.00
EFT8750	02/02/2015	PURCHER INTERNATIONAL	CHARGES	M		31.26
EFT8751	02/02/2015	PEMCO DIESEL PTY LTD	CHARGES	M		150.65
EFT8752	02/02/2015	WESTRAC PTY LTD	CHARGES	M		4,598.34
EFT8753	09/02/2015	FIVE STAR BUSINESS EQUIPMENT & COMMUNICATIONS	LEASE	M		421.30
EFT8754	09/02/2015	NAB BUSINESS VISA	CREDIT CARD	M		1,053.14
EFT8755	09/02/2015	FIVE STAR BUSINESS EQUIPMENT & COMMUNICATIONS	CHARGES	M		943.67
EFT8756	09/02/2015	Australian Taxation Office	BAS	M		13,950.00

Date: 09/03/2015
Time: 12:27:44PM

MINGENEW SHIRE COUNCIL ORDINARY MEETING AGENDA – 18 March 2015
Shire of MINGENEW
List of accounts for February 2015

USER: SFO
PAGE: 2

Cheque /EFT No	Date	Name	Invoice Description	Bank Code	INV Amount	Amount
EFT8757	09/02/2015	AMPAC	CHARGES	M		1,078.22
EFT8758	09/02/2015	Australian Communications And Media Authority	LICENCE	M		103.00
EFT8759	09/02/2015	Asphalt In A Bag	CHARGES	M		1,718.75
EFT8760	09/02/2015	ASB MARKETING	UNIFORM	M		443.74
EFT8761	09/02/2015	BATAVIA COAST AUTO ELECTRICAL PTY LTD	CHARGES	M		1,864.00
EFT8762	09/02/2015	Courier Australia	FREIGHT	M		349.50
EFT8763	09/02/2015	Martine Coremans	CHARGES	M		630.00
EFT8764	09/02/2015	DONGARA DRILLING & ELECTRICAL	CHARGES	M		2,699.24
EFT8765	09/02/2015	DELTAZONE NOMINEES PTY LTD	CHARGES	M		44.00
EFT8766	09/02/2015	TRADELINK	CHARGES	M		541.82
EFT8767	11/02/2015	Shire of Mingenew - Payroll	PAYROLL11022015	M		29,022.80
EFT8768	11/02/2015	Australian Services Union	Payroll deductions	M		25.10
EFT8769	11/02/2015	CHILD SUPPORT AGENCY	Payroll deductions	M		262.21
EFT8770	11/02/2015	LGRCEU	Payroll deductions	M		19.40
EFT8771	16/02/2015	DONGARA DRILLING & ELECTRICAL	CHARGES	M		60.91
EFT8772	16/02/2015	Dongara Tyrepower	TYRES	M		760.00
EFT8773	16/02/2015	DONGARA QUALITY MEATS	CHARGES	M		70.00
EFT8774	16/02/2015	EJ DIESEL	CHARGES	M		567.38
EFT8775	16/02/2015	Great Northern Rural Services	CHARGES	M		264.80

Date: 09/03/2015
Time: 12:27:44PM

MINGENEW SHIRE COUNCIL ORDINARY MEETING AGENDA – 18 March 2015
Shire of MINGENEW
List of accounts for February 2015

USER: SFO
PAGE: 3

Cheque /EFT No	Date	Name	Invoice Description	Bank Code	INV Amount	Amount
EFT8776	16/02/2015	HARCOURTS DONGARA REAL ESTATE	CHARGES	M		2,819.62
EFT8777	16/02/2015	RELIANCE PETROLEUM	FUEL	M		14,072.57
EFT8778	16/02/2015	PEMCO DIESEL PTY LTD	CHARGES	M		2,720.80
EFT8779	16/02/2015	PRIME MEDIA GROUP PTY	CHARGES	M		2,200.00
EFT8780	16/02/2015	Shire Of Three Springs	CHARGES	M		4,093.24
EFT8781	16/02/2015	WESTERN AUSTRALIAN TREASURY CORPORATION	LOAN 141	M		15,279.24
EFT8782	16/02/2015	WESTRAC PTY LTD	CHARGES	M		8,363.12
EFT8783	16/02/2015	MINGENEW FABRICATORS	CHARGES	M		288.75
EFT8784	23/02/2015	SGFLEET	LEASE	M		1,333.80
EFT8785	23/02/2015	LEADING EDGE COMPUTERS	GOODS	M		25.00
EFT8786	23/02/2015	Courier Australia	FREIGHT	M		62.79
EFT8787	23/02/2015	CENTRAL WEST CONCRETE	CHARGES	M		4,526.50
EFT8788	23/02/2015	LANDGATE	CHARGES	M		62.35
EFT8789	23/02/2015	DORMA	CHARGES	M		1,022.23
EFT8790	23/02/2015	EJ DIESEL	CHARGES	M		526.20
EFT8791	23/02/2015	GERALDTON TV & RADIO SERVICES	CHARGES	M		338.60
EFT8792	23/02/2015	Great Northern Rural Services	CHARGES	M		668.70
EFT8793	23/02/2015	SHIRE OF IRWIN	FEES	M		263.08
EFT8794	23/02/2015	IRWIN PLUMBING SERVICES	CHARGES	M		464.20

Date: 09/03/2015
Time: 12:27:44PM

MINGENEW SHIRE COUNCIL ORDINARY MEETING AGENDA – 18 March 2015
Shire of MINGENEW
List of accounts for February 2015

USER: SFO
PAGE: 4

Cheque /EFT No	Date	Name	Invoice Description	Bank Code	INV Amount	Amount
EFT8795	23/02/2015	CANINE CONTROL	FEES	M		986.17
EFT8796	23/02/2015	RELIANCE PETROLEUM	FUEL	M		4,070.93
EFT8797	23/02/2015	MINGENEW IGA	CHARGES	M		445.06
EFT8798	23/02/2015	MIDWEST AERO MEDICAL AIR AMBULANCE P/L	FEES	M		1,000.00
EFT8799	23/02/2015	MINGENEW SPRING CARAVAN PARK	CHARGES	M		314.00
EFT8800	23/02/2015	PEMCO DIESEL PTY LTD	CHARGES	M		6,514.32
EFT8801	23/02/2015	PRIME MEDIA GROUP PTY	CHARGES	M		3,074.50
EFT8802	23/02/2015	RECORDS ARCHIVES & HISTORICAL MANAGEMENT	CHARGES	M		2,475.00
EFT8803	23/02/2015	LANDMARK	GOODS	M		548.82
EFT8804	23/02/2015	WESTERN AUSTRALIAN TREASURY CORPORATION	LOAN 139	M		16,744.17
EFT8805	23/02/2015	MINGENEW FABRICATORS	CHARGES	M		1,711.52
EFT8806	25/02/2015	Shire of Mingenew - Payroll	PAYROLL25022015	M		28,952.90
EFT8807	25/02/2015	Australian Services Union	Payroll deductions	M		25.10
EFT8808	25/02/2015	CHILD SUPPORT AGENCY	Payroll deductions	M		262.21
EFT8809	25/02/2015	LGRCEU	Payroll deductions	M		19.40
DD7044.1	11/02/2015	WA SUPER	Payroll deductions	M		6,610.77
DD7044.2	11/02/2015	PERSONAL CHOICE PRIVATE FUND EWRAP SUPER	Superannuation contributions	M		1,051.20
DD7044.3	11/02/2015	PRIME SUPER	Superannuation contributions	M		195.88

Date: 09/03/2015
 Time: 12:27:44PM

MINGENEW SHIRE COUNCIL ORDINARY MEETING AGENDA – 18 March 2015
Shire of MINGENEW
List of accounts for February 2015

USER: SFO
 PAGE: 5

Cheque /EFT No	Date	Name	Invoice Description	Bank Code	INV Amount	Amount
DD7044.4	11/02/2015	AMP Corporate Superannuation	Superannuation contributions	M		178.94
DD7060.1	25/02/2015	WA SUPER	Payroll deductions	M		6,533.07
DD7060.2	25/02/2015	PERSONAL CHOICE PRIVATE FUND EWRAP SUPER	Superannuation contributions	M		1,051.20
DD7060.3	25/02/2015	PRIME SUPER	Superannuation contributions	M		195.88
DD7060.4	25/02/2015	AMP Corporate Superannuation	Superannuation contributions	M		178.94

REPORT TOTALS

Bank Code	Bank Name	TOTAL
M	MUNI - NATIONAL AUST BANK	220,547.29
T	TRUST- NATIONAL AUST BANK	2,200.00
TOTAL		222,747.29

NATIONAL BUSINESS MASTERCARD

01 February to 28 February 2015

CEO - Martin Whitley

Fuel	\$	50.00
Fuel	\$	50.00
Fan Belt for Toro	\$	13.95
Bank Fees	\$	9.00
	\$	122.95

Work's Manager - Warren Borrett

Licence Mick Warren	\$	128.70
Battery	\$	295.90
Uniform	\$	125.00
Bearings	\$	85.80
Bank Fees	\$	9.00
	\$	644.40

Manager of Admin and Finance - Nita Jane

Internet Fees	\$	209.90
Beer for meetings	\$	306.93
Parking	\$	20.00
Title search	\$	24.00
Bank Fees	\$	9.00
	\$	569.83

Total Direct Debit Payment made on 2nd March 2015	\$	1,337.18
--	-----------	-----------------

POLICE LICENSING
Direct Debits from Muni Account
01 February to 28 February 2015

Monday, 2 February 2015	\$	59.20
Wednesday, 4 February 2015	\$	107.65
Thursday, 5 February 2015	\$	2,063.95
Friday, 6 February 2015	\$	559.70
Monday, 9 February 2015	\$	557.15
Tuesday, 10 February 2015	\$	11,058.20
Wednesday, 11 February 2015	\$	223.50
Thursday, 12 February 2015	\$	334.30
Monday, 16 February 2015	\$	7,365.30

Tuesday, 17 February 2015	\$ 376.50
Wednesday, 18 February 2015	\$ 327.35
Thursday, 19 February 2015	\$ 35.40
Friday, 20 February 2015	\$ 335.80
Monday, 23 February 2015	\$ 5,133.10
Tuesday, 24 February 2015	\$ 217.05
Wednesday, 25 February 2015	\$ 383.20
Thursday, 26 February 2015	\$ 668.96
Friday, 27 February 2015	\$ 18,193.75
	\$ 48,000.06

BANK FEES

Direct debits from Muni Account 01 February to 28 February 2015

Total direct debited from Municipal Account	\$ 85.49
---	-----------------

PAYROLL

Direct Payments from Muni Account 01 February to 28 February 2015

Wednesday, 11th February 2015	\$ 42,929.94
Wednesday, 25th February 2015	\$ 42,868.92
	\$ 85,798.86

9.3 PLANNING AND BUILDING

9.3.1 PROPOSED EQUIPMENT SHELTER ON LOT 33 DEPOT HILL ROAD, MINGENEW

Location/Address:	Lot 33 Depot Hill Road, Mingenew
Name of Applicant:	Kordia Solutions Australia on behalf of Australian Maritime Safety Authority
File Reference:	ADM0261
Disclosure of Interest:	Nil
Date:	13 th March, 2015
Author:	Arqum Hayat, Planning Officer (Shire of Irwin)
Senior Officer:	Martin Whitely, Chief Executive Officer

Summary

Planning approval is recommended for a proposed equipment shelter at Lot 33 Depot Hill Road, Mingenew, subject to conditions and advice notes.

Attachment

Planning Application and Scheme Map.

Background

The Applicant proposes a shelter is to be used to store satellite communications equipment on Lot 33 Depot Hill Road. The landowner is Alex Pearse. As per the email sent by the applicant, the development is for 'an unmanned facility that house satellite communications equipment'. The proposed maximum height is 2.6m, and proposed dimensions are 8.4m (length) by 3m (width). The shelter will contain a toilet. Effluent disposal arrangements will be required for the shelter.

The site is zoned Rural/Mining under the Shire of Mingenew's Local Planning Scheme (LPS) No.3 (the Scheme) and is located north of the Mingenew Townsite (see Attachment 1).

The majority of the lot is leased from the owner to Universal Space Network, who have built a satellite tracking station. This application refers to a 10.1ha area leased to the Australian Maritime Safety Authority. The subject site consists of vacant farmland on which the shelter shall be built on.

COMMENT

As the 'land use' is already in existence on the lot (Universal Space Network), Planning Approval is only required for the 'development'. The proposed development is consistent with the site's existing land use. The established land use is 'telecommunications infrastructure'.

The proposed development meets the scheme provisions for setbacks. There is no requirement for parking for this type of development under the Scheme. As the proposed development meets the relevant provisions of the Scheme, approval is recommended.

Consultation

The Shire of Irwin's Development Control Unit has no objections in principle, and advice that effluent disposal arrangements should be to the satisfaction of the State Government's Department of Health (see Condition 2 below).

Statutory Environment

Shire of Mingenew Local Planning Scheme No.3

Policy Implications

Nil

Financial Implications

Nil

Strategic Implications

Nil

Voting Requirements

Simple Majority

OFFICER RECOMMENDATION – ITEM 9.3.1

That Council resolve to approve the proposed Equipment Shelter on Lot 33 Depot Hill Road, Mingenew subject to the following Conditions and Advice notes:

Conditions:

1. The approved development shall be in accordance with the attached stamped approved plans, dated 17 March 2015.
2. A minimum of one car parking bay shall be provided on-site in accordance with the requirements of Australian Standard AS2890.1:2004 Parking Facilities – Off-street Car Parking. Vehicle parking, manoeuvring and circulation areas shall be maintained to a minimum all-weather standard (e.g. gravel, crushed rock) to facilitate access to the development by 2 wheel drive vehicles.
3. Prior to the commencement of development, the applicant is to submit a parking plan in accordance with Condition 2 above.
4. The approved development shall be connected to an effluent disposal system to the satisfaction of the Shire of Irwin (see Advice note 2).
5. The approved development shall only be used for the storage of satellite communications equipment involved in the operation of the site, and shall not be used for human habitation.
6. All stormwater and drainage runoff from all roofed and impervious areas is to be retained on-site to the satisfaction of the Shire of Mingenew.
7. Any soils disturbed or deposited on the site shall be stabilised and retained on site to the satisfaction of the Shire of Mingenew.

Advice Notes

1. In accordance with the Building Act, the approved development requires a Building Permit.
2. An Application to Construct or Install an Apparatus for the Treatment of Sewage will need to be submitted. The application must outline details of any existing system and/or details of proposed system. A plan must be included with the application showing locations of tanks, drains, pipes, disconnecter trap and vent pipe as well as location of toilets, hand basins etc, clearly differentiating between existing and proposed features. Plans must include location of proposed tanks/drains with respect to any existing or proposed buildings and property boundaries.
3. It is the responsibility of the applicant to ensure that building setbacks correspond with the legal description of the land. This may necessitate re-surveying and re-pegging the site. The Shire of Mingenew will take no responsibility for incorrectly located buildings.
4. It is the responsibility of the applicant/owner to search the title of the property to ascertain the presence of any easements and/or restrictive covenants that may apply.

SCHEDULE 6 — FORM OF APPLICATION FOR PLANNING APPROVAL

Application for planning approval

Owner details		
Name: <u>ALEXANDER THOMAS KENNEDY PEARSE (ALEX PEARSE PTY LTD)</u>		
Address: <u>488 YARRAGUADGE WEST RD, PO BOX 1189</u> <u>MINGENEW</u> Postcode: <u>6522</u>		
Phone: <u>0899291041</u> (work)	Fax:	E-mail:
(home): <u>042729440</u> (mobile):	<u>0899291044</u>	<u>YATHARAGUADGE BAYVIEW.COM</u>
Contact person: <u>ALEX PEARSE</u>		
Signature: 		Date: <u>05/03/15</u>
Signature:		Date:
<i>The signature of the owner(s) is required on all applications. This application will not proceed without that signature.</i>		

Applicant details		
Name: <u>KORDIA SOLUTIONS AUSTRALIA</u>		
Address: <u>LEVEL 2, 4 DRAKE AVE</u> <u>MACQUARIE PARK NSW</u> Postcode: <u>2113</u>		
Phone: <u>02 9856 2633</u> (work)	Fax:	E-mail:
(home): <u>0417699935</u> (mobile):		<u>Kelvin.Phillips@Kordia.com.au</u>
Contact person for correspondence: <u>KELVIN PHILLIPS</u>		
Signature: 		Date: <u>05/03/2015</u>

Property details		
Lot No: <u>33</u>	House/Street No:	Location No:
Diagram or Plan No: <u>DP 68473</u>	Certificate of Title Vol. No:	Folio:
Diagram or Plan No:	Certificate of Title Vol. No:	Folio:
Title encumbrances (e.g. easements, restrictive covenants):		
Street name: <u>DEPOT HILL RD</u> Suburb: <u>NANGETTY MINGENEW</u>		
Nearest street intersection:		

Existing building/land use: Rural Farm Land
Description of proposed development and/or use: MEOSAR satellite facility, satellite antennas and prefabricated equipment shelter on concrete pads.
Nature of any existing buildings and/or use: Farm land no existing buildings
Approximate cost of proposed development: \$400,000
Estimated time of completion: June 2015

<i>OFFICE USE ONLY</i>	
Acceptance Officer's initials:	Date received:
Local government reference no:	

PARTICULARS REQUIRED WITH APPLICATIONS

Accompanying material

Unless the local government waives any particular requirement every application for planning approval is to be accompanied by —

- (a) a plan or plans to a scale of not less than 1:500 showing —
 - (i) the location of the site including street names, lot numbers, north point and the dimensions of the site;
 - (ii) the existing and proposed ground levels over the whole of the land the subject of the application and the location, height and type of all existing structures, and structures and vegetation proposed to be removed;
 - (iii) the existing and proposed use of the site, including proposed hours of operation, and buildings and structures to be erected on the site;
 - (iv) the existing and proposed means of access for pedestrians and vehicles to and from the site;
 - (v) the location, number, dimensions and layout of all car parking spaces intended to be provided;
 - (vi) the location and dimensions of any area proposed to be provided for the loading and unloading of vehicles carrying goods or commodities to and from the site and the means of access to and from those areas;
 - (vii) the location, dimensions and design of any open storage or trade display area and particulars of the manner in which it is proposed to develop the same; and
 - (viii) the nature and extent of any open space and landscaping proposed for the site;
- (b) plans, elevations and sections of any building proposed to be erected or altered and of any building it is intended to retain;
- (c) any specialist studies that local government may require the applicant to undertake in support of the application such as traffic, heritage, environmental, engineering or urban design studies; and
- (d) any other plan or information that the local government may require to enable the application to be determined.

Proposed outbuilding on lot 33 Depot Hill Rd,
Mingenew.

DCU Comments

Building Department Comments:

Building Application will detail storm footing etc.

[Signature] 9/3/15.

Health Department comments:

Septic Tank application required.

[Signature] 9/3/15.

Received
9/3/15

APPLICANT

PHOTOS FROM





PHOTOS FROM S40 (MINGENEW) 9/3/15





Arqum Hayat

From: Kelvin Phillips [Kelvin.Phillips@kordia.com.au]
Sent: Tuesday, 17 February 2015 10:58 AM
To: Arqum Hayat
Subject: RE: Proposed Transportable Hut
Attachments: W100000_VERSION 2 CENTRED SHELTER.PDF; Floor_Plan_&_Elevations.pdf; ATT00001.txt

G'day Arqum,

Attached is the proposed installation this is only a draft and will be modified to the final solution. This is a Satellite facility on behalf of AMSA (Australian Maritime Safety Authority) and the shelter will be similar to the one attached with 2 diesel backup generators on a 10m x 10m concrete slab. This an unmanned facility that house satellite communications equipment. The current use of the land is for farming and the land next door to the SSC space facility. I will expect the final plans to be completed in 2-3 weeks. Can you send me any forms that are required.

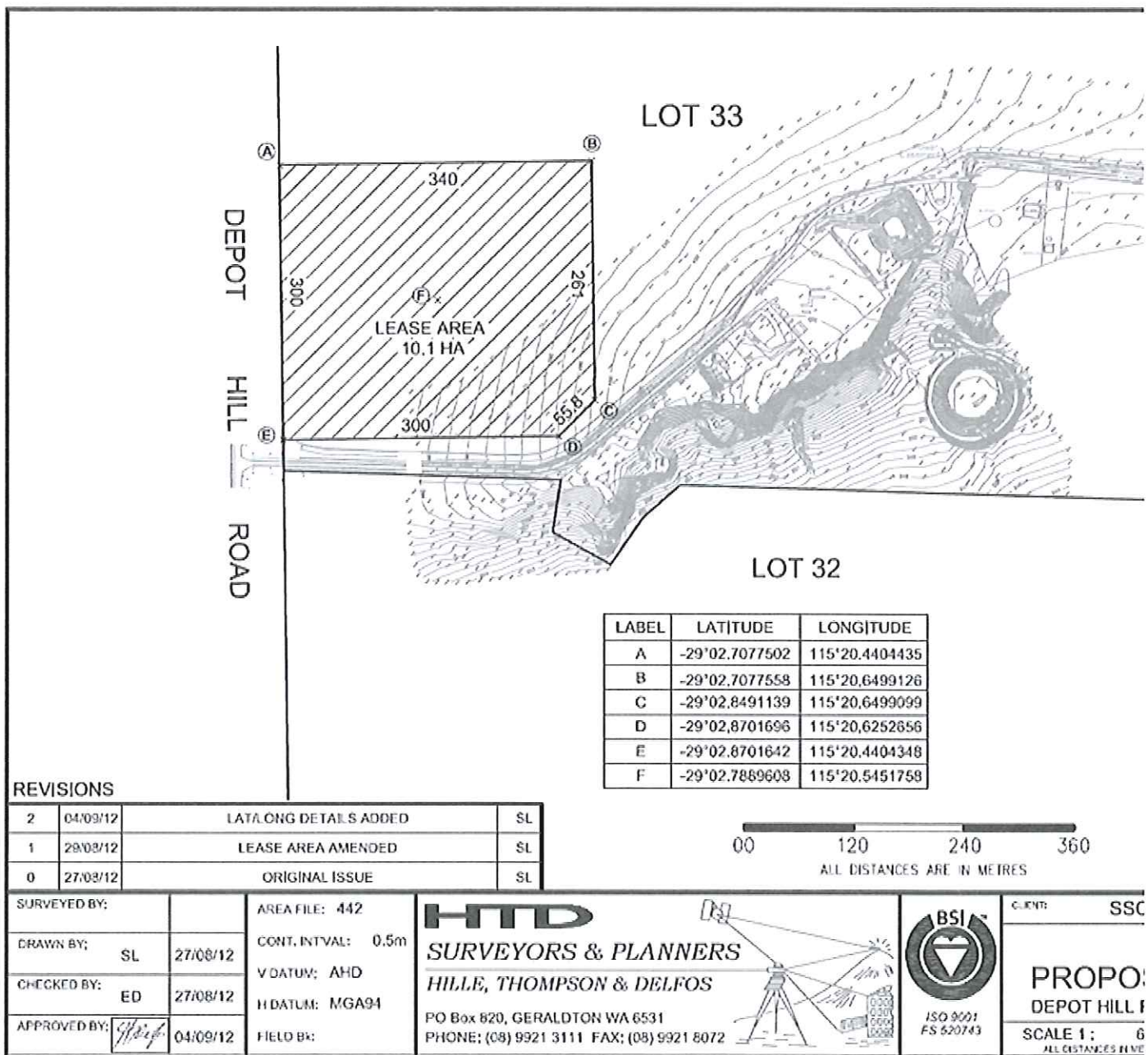

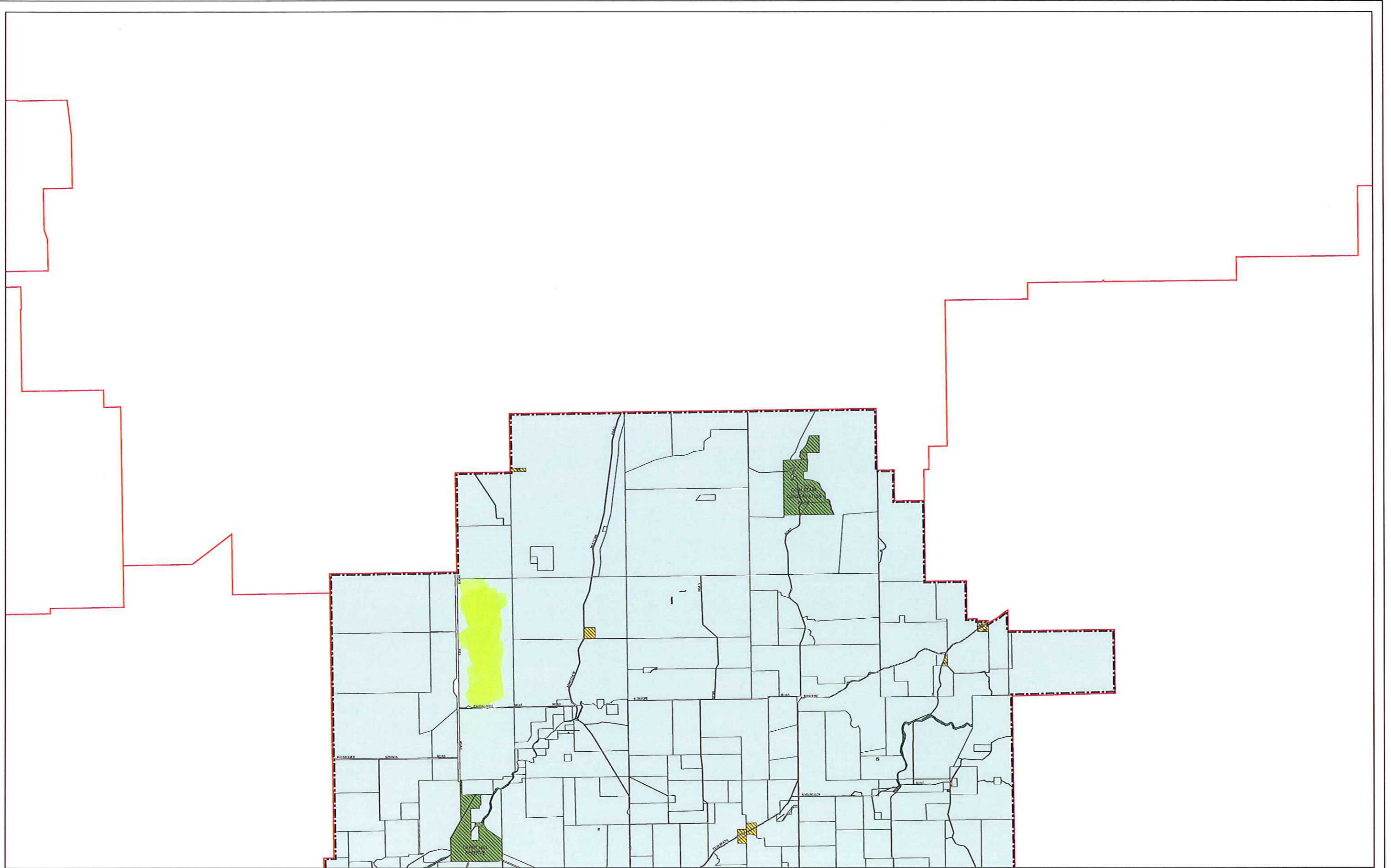

Produced by Mapping and GeoSpatial Data Branch,
Department of Planning
Whilst all care has been taken to accurately portray the
current Scheme provisions, no responsibility shall be
taken for any omissions or errors in this documentation.
Consultation with the respective Local Government
should be made to view a legal version of the Scheme.
Please advise the Department of Planning of any
omissions or errors in the document.
Base Information Supplied by the Western
Australian Land Information Authority. GL248.2007.2

SHIRE OF MINGENEW
LOCAL PLANNING SCHEME NO 3
(DISTRICT SCHEME)

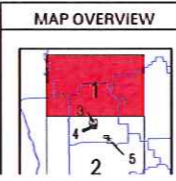

Authorised: Victor Chew
Plot date: 13 Sep 2011
G.Gazette: 18-April-2008

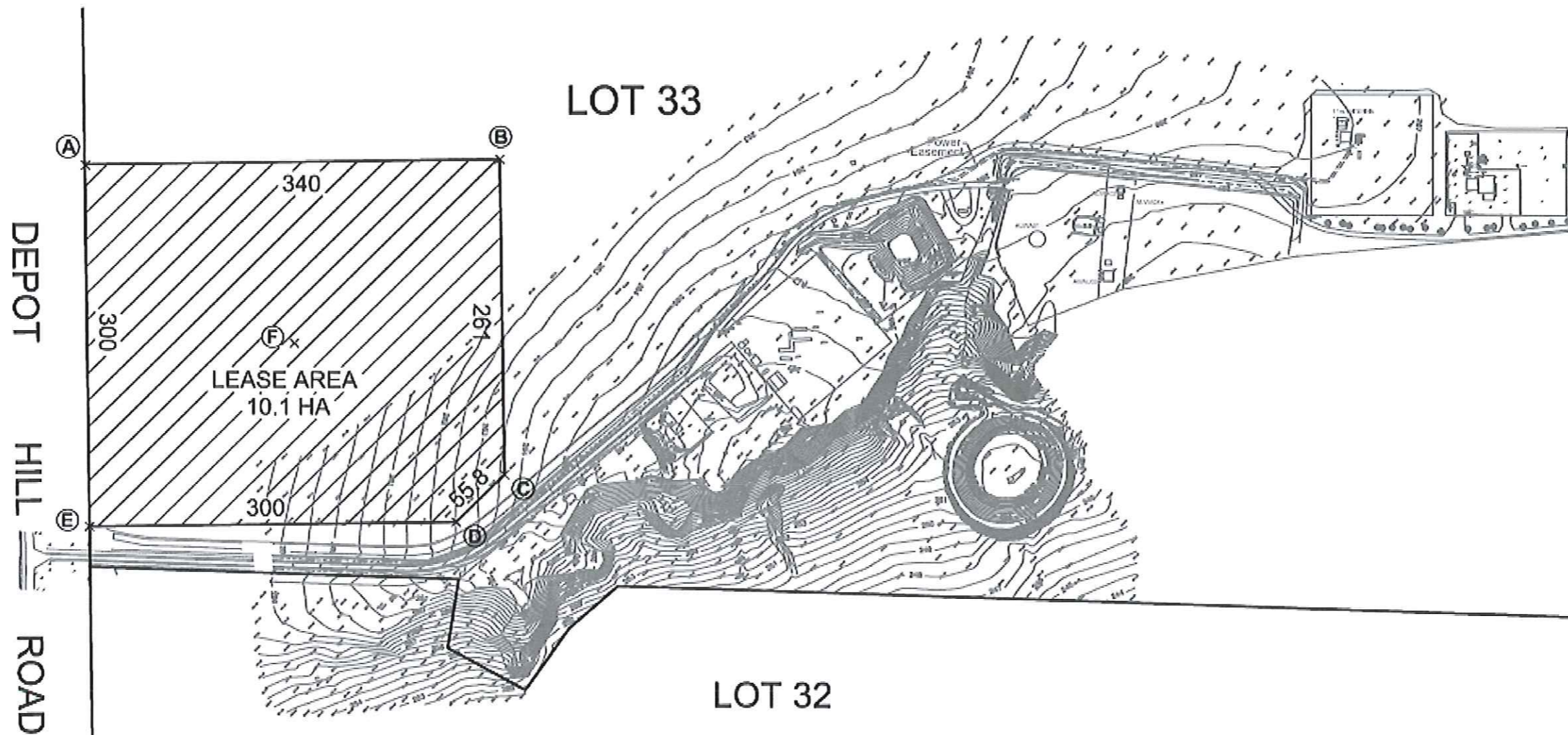

LABEL	LATITUDE	LONGITUDE
A	-29°02.7077502	115°20.4404435
B	-29°02.7077558	115°20.6499126
C	-29°02.8491139	115°20.6499099
D	-29°02.8701696	115°20.6252656
E	-29°02.8701642	115°20.4404348
F	-29°02.7889608	115°20.5451758

REVISIONS

NO	DATE	DESCRIPTION	BY
2	04/09/12	LAT/LONG DETAILS ADDED	SL
1	29/08/12	LEASE AREA AMENDED	SL
0	27/08/12	ORIGINAL ISSUE	SL

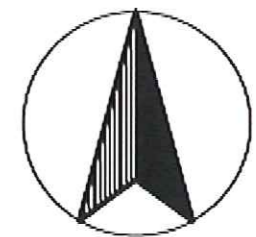
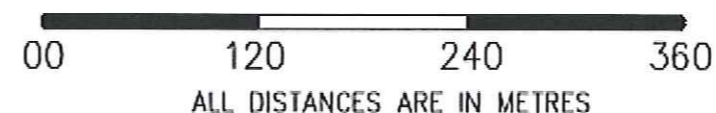

SURVEYED BY:		AREA FILE: 442	<p>SURVEYORS & PLANNERS HILLE, THOMPSON & DELFOS PO Box 820, GERALDTON WA 6531 PHONE: (08) 9921 3111 FAX: (08) 9921 8072</p>	<p>ISO 9001 FS 520743</p>	CLIENT: SSC SPACE AUSTRALIA PTY LTD
DRAWN BY: SL	27/08/12	CONT. INT'VAL: 0.5m			Lot 33 on DP68473
CHECKED BY: ED	27/08/12	V DATUM: AHD H DATUM: MGA94			PROPOSED AMSA LEASE AREA DEPOT HILL ROAD, NANGETTY - SHIRE OF MINGENEW
APPROVED BY:	04/09/12	FIELD Bk:			SCALE 1 : 6000 ALL DISTANCES IN METRES
					SHEET SIZE: A4
					DWG No. 37312LE1-1-2

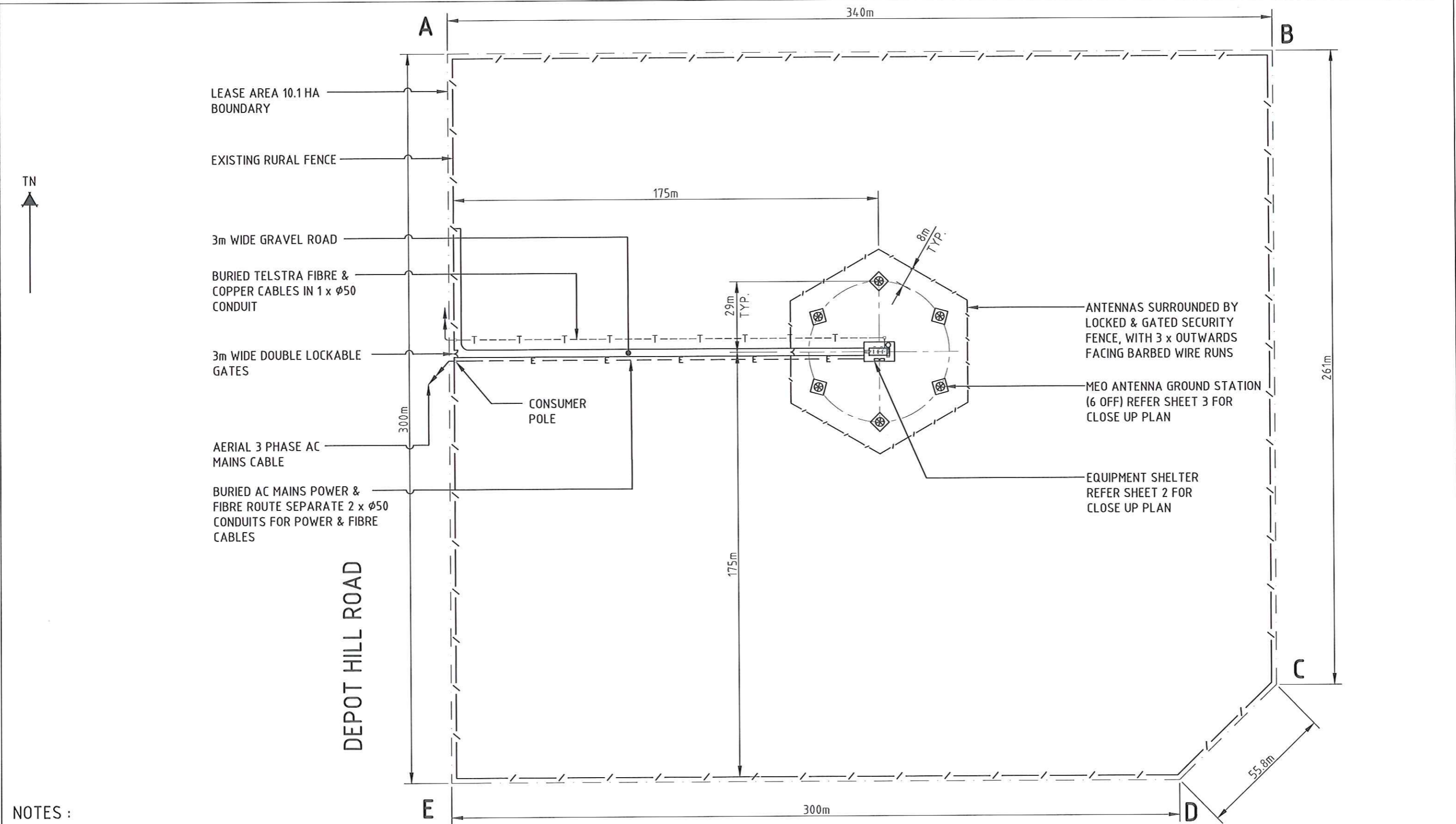

NOTES :
 1. ALL DIMENSIONS ARE IN MILLIMETERS UNLESS OTHERWISE STATED.

OVERALL SITE LAYOUT

SCALE 1:1500
 15m 0 75m SCALE 1:1500

TITLE	ORDER	DRAWN	CHKD	AMENDMENT	EXAM	APPD	DATE	ISS	© Copyright Kordia™. All rights reserved.	
MEO GROUND STATION: MEO ANTENNA	-	MS	KP	FOR APPROVAL	KP	KP	03.03.15	A	DRAWN: MS	DWG No. W100000
AMSA MEOSAR SITE									DRG CHK: KP	
WA SPACE CENTRE, MINGENEW, WA									DESIGN CHK: KP	SHEET
OVERALL SITE LAYOUT									DATE: 03.03.15	ISSUE
									SIZE PAGE: A3	01 A

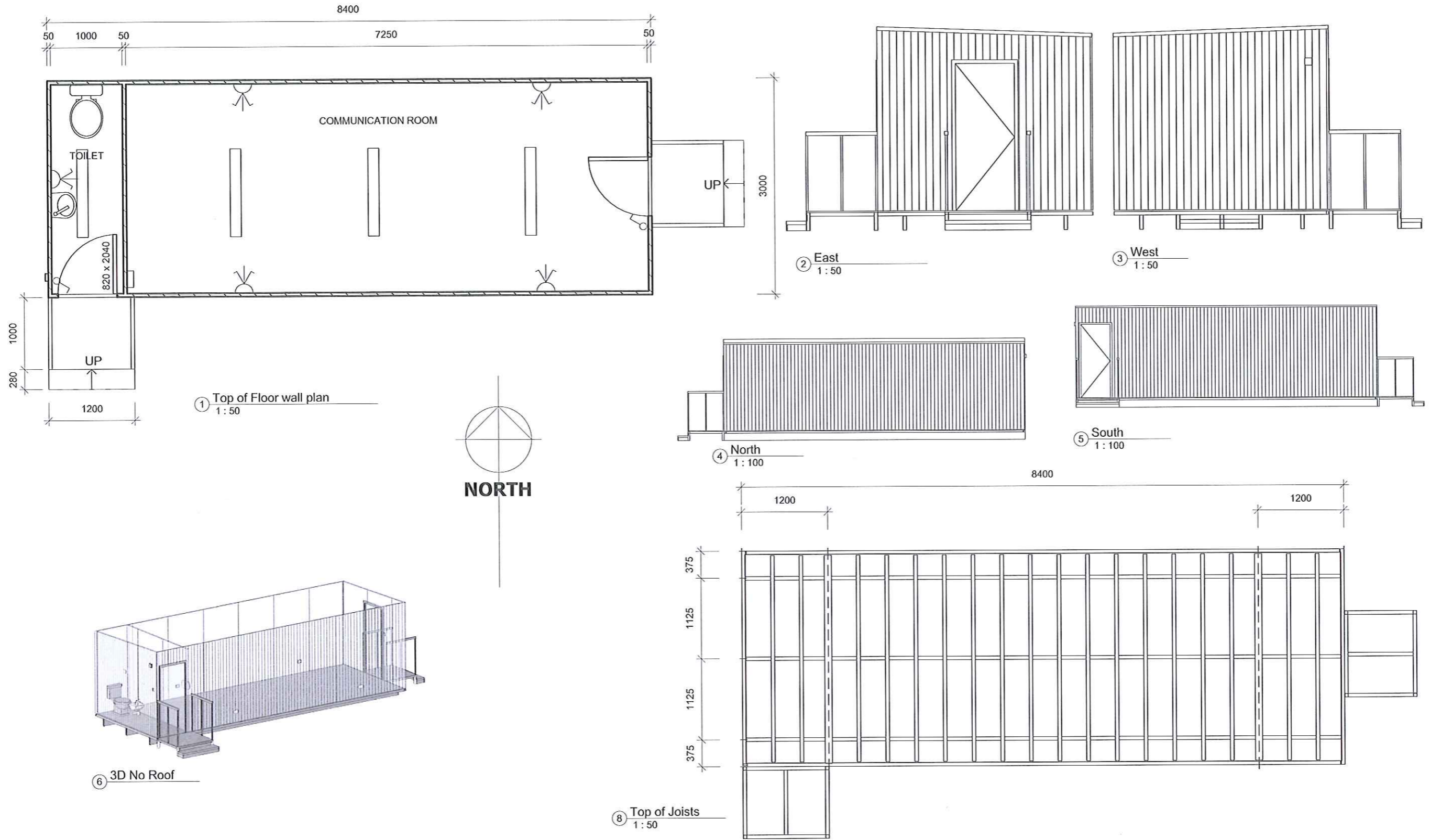

UNIQUE
MODULAR BUILDINGS
37 Capital Link Drive, Campbellfield VIC 3061
Ph: (03) 9357 0566
Fax: (03) 93579319
www.uniquemb.com.au

THIS DRAWING IS COPYRIGHT AND THE PROPERTY OF UNIQUE MODULAR BUILDINGS. ABN 45 092 754 704 IT IS SUBJECT TO THEIR RECALL AND MAY NOT BE REPRODUCED OR ITS CONTENTS BE DIVULGED WITHOUT WRITTEN AUTHORITY.

No.	Description	Date

Project number	Project Number
Date	02/08/2013
Drawn by	S L ANDREW
Checked by	Checker
Scale	As indicated
SHT 1	

8.4M x 3.0M COMMUNICATION ROOM
KORDIA
FLOOR PLAN, ELEVATIONS & 3D VIEW

8/8/2013 16:43:03

TN

RECOMMENDED LAYOUT FOR 6 MEO ANTENNA GROUND STATION:

1. MINIMUM REQUIRED SPACE: 1482.7 m²
2. EACH RADOME REQUIRES A 5.5m x 5.5m x 0.2m CONCRETE PAD.
3. SEPARATION BETWEEN THE RADOMES SHOULD BE 20m AT MINIMUM.

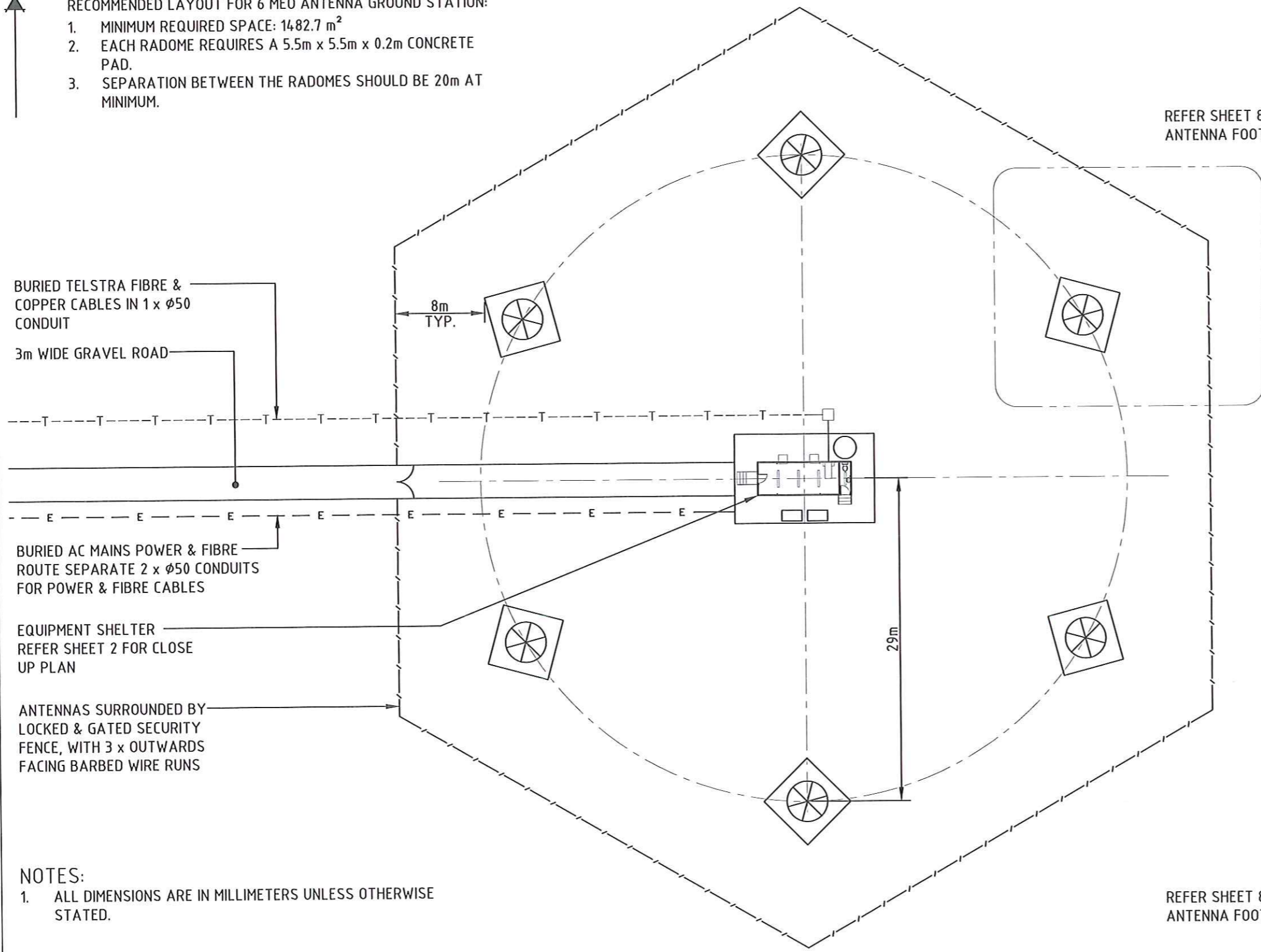

REFER SHEET 8 FOR MEO ANTENNA FOOTING DETAILS.

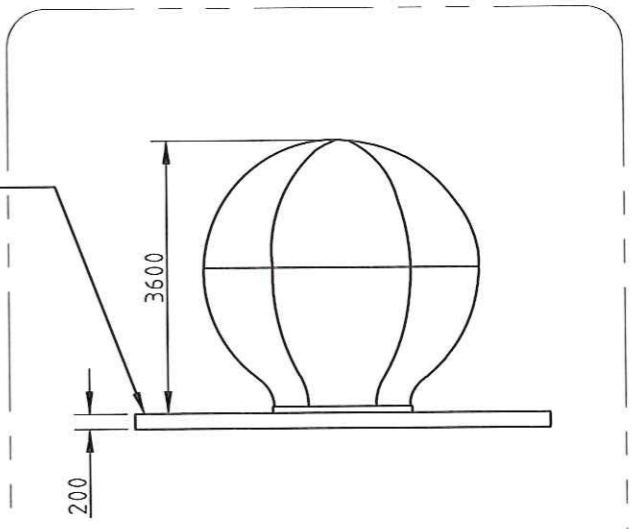

ELEVATION
SCALE 1:100

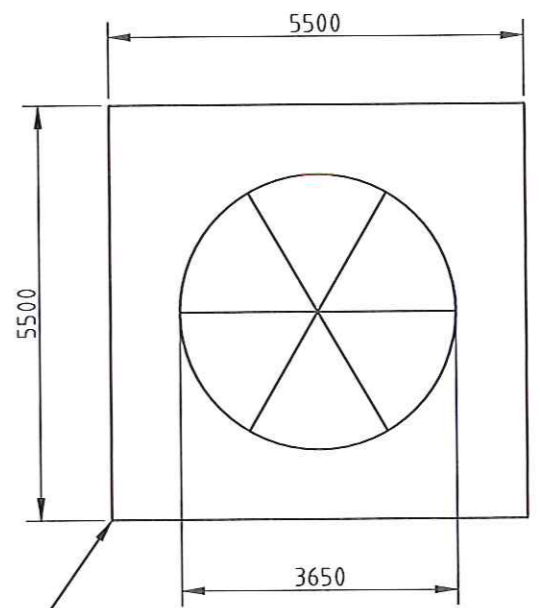

PLAN VIEW
SCALE 1:100

REFER SHEET 8 FOR MEO ANTENNA FOOTING DETAILS.

- NOTES:
1. ALL DIMENSIONS ARE IN MILLIMETERS UNLESS OTHERWISE STATED.

MEO ANTENNA GROUND STATION CLOSE UP PLAN (6 OFF)

SCALE 1:400
4m 0 4m 8m 12m 16m 20m SCALE 1:400

1m 0 1m 2m 3m 4m 5m SCALE 1:100

TITLE	ORDER	DRAWN	CHKD	AMENDMENT	EXAM	APPD	DATE	ISS
MEO GROUND STATION: MEO ANTENNA	-	MS	KP	FOR APPROVAL	KP	KP	03.03.15	A
AMSA MEOSAR SITE								
WA SPACE CENTRE, MINGENEW, WA								
MEO ANTENNA GROUND STATION CLOSE UP PLAN								

© Copyright Kordia™. All rights reserved.

DRAWN: MS	DWG No. W100000
DRG CHK: KP	SHEET 03
DESIGN CHK: KP	ISSUE A
DATE: 03.03.15	
SIZE PAGE: A3	

- 10.0 ELECTED MEMBERS/MOTIONS OF WHICH PREVIOUS NOTICE HAS BEEN GIVEN**
- 11.0 NEW BUSINESS OF AN URGENT NATURE INTRODUCED BY DECISION OF MEETING**
 - 11.1 ELECTED MEMBERS**
 - 11.2 STAFF**
- 12.0 CONFIDENTIAL ITEMS**

Nil
- 13.0 TIME AND DATE OF NEXT MEETING**

Next Ordinary Council Meeting to be held on Wednesday 15th April 2015 commencing at 4.00pm.
- 14.0 CLOSURE**